

METERING & SES

TITLE / DESCRIPTION	PAGE
Location Requirements	9-1-1
Equipment / Meter Rooms	9-1-2
Lock Box & Seals.....	9-1-7
Service Disconnect Requirements.....	9-2-1
Addressing and Identification.....	9-3-1
Self-Contained Meter Sockets	9-4-1
Current Transformer Meter Sockets	9-4-3
Equipment Responsibility	9-5-1
Switchboard, Self-Contained w/ Factory-Installed Test Block Bypass, Commercial/Residential, 200 A Max.....	9-6-1
Self-Contained w/ Factory-Installed Test Block Bypass, Commercial/Residential, 100 A Max.....	9-7-1
Self-Contained w/ Factory-Installed Test Block Bypass & Service Disconnect, Commercial/Residential, 200 A Max.....	9-8-1
Test Block Bypass, Factory-Installed Commercial/Residential, 200 A Max.	9-9-1
Test Block Bypass, Factory-Installed Commercial/Residential, 200 A Max., Bussed/Cable Terminations.....	9-10-1
Switchboards, General Information	9-11-1
Switchboards, Current Transformer Compartment with Filler Panel	9-12-1
Switchboard, Low-Profile, 1,000 A Max.....	9-13-1
Switchboard, Combination Pull Section, 1,000 A Max.....	9-14-1
Switchboards, Current Transformer Meter Panel Clearance, Outdoor	9-15-1
Switchboards, General Information, Barrier Illustration	9-16-1
Test Switch Mounting Base, Removable Wall-Mounted SES.....	9-17-1
Switchboards, 0-600 Volts, Instrument Transformer Compartment, 1Ø, 3-Wire, 400-1,000 Amps	9-18-1
Switchboards, 0-600 Volts, Instrument Transformer Compartment, 3Ø, 4-Wire Service, 400-1,000 Amps	9-19-1
Switchboards, 0-600 Volts, Instrument Transformer Compartment, 3Ø, 4-Wire Service, 1,001-3,000 Amps	9-20-1
Switchboards, 0-600 Volts, Instrument Transformer Compartment, 3Ø, 4-Wire, 3,001 Amps & Larger.....	9-21-1
Switchboards, 0-600 Volts, Current Transformer Compartment, with 4" Bus, Removable Link and Current Transformer Support.....	9-22-1

	<h3 style="margin: 0;">METERING & SES</h3>	ISSUE DATE: 11/16/12 REV. DATE: 07/22/25 APPROVAL: J. Robbins
	9-i	ESS-Index-9.doc

METERING & SES

Switchboards, 0-600 Volts, Current Transformer Compartment, with 5" Bus, Removable Link and Current Transformer Support	9-23-1
Switchboard, 0-600 Volts, 15" Hinged Meter Panel	9-24-1
Combination Disconnecting Device and Terminating Enclosure, 1,200 Amps Maximum, 0-600 Volts	9-25-1
Commercial and Residential Use, Underground Pull Section, 800 Amps Maximum	9-26-1
Wall-Mounted Pull Section with Cable Terminating Facilities (Mechanical Lugs), 1-600 Volts, 1200 Amps Maximum	9-27-1
Switchboard Pull Section	9-28-1
Terminating Facilities, Underground Pull Boxes or Pull Sections	9-29-1
Medium Voltage, General Requirements	9-30-1
Medium Voltage, Enclosure Requirements	9-31-1
Medium Voltage, Bus & Termination Requirements	9-32-1
Medium Voltage, Hinged Meter Panel with Single Socket	9-33-1
Medium Voltage, Metering Enclosure	9-34-1
Medium Voltage, Instrument Transformer Mounting Pattern	9-35-1
Medium Voltage, Indoor Current Transformer Dimensions (for Metering Purposes)	9-36-1
Medium Voltage, Underground Service, Terminating Pull Section	9-37-1
Overhead / Underground Service, Die-Cast and Square-Base Sockets	9-38-1

SRP reserves the right to determine all SES locations. Only authorized personnel of SRP's Distribution Design Department will determine this location.

1. Meter Location Requirements

All SES/meter locations require approval prior to design and construction from Distribution Design. Meters shall be Readily Accessible for reading, maintenance and emergencies.

- A. Factory-built Buildings must comply with the following additional requirements:
 - 1) Secured to a permanent foundation (as approved and documented by local AHJ).
 - 2) Trailer tongue and axles shall be removed.
 - 3) Meter panel mounted on Building at plant.
- B. For residential SES location requirements, see Section 5 – SES, Equipment Locations & Heights.
- C. Each SES shall meet all SRP requirements in Section 9.
- D. If the Customer desires to have the meters in a meter room, or if the complex is secured or access is otherwise restricted, a lock box will be required at Customer's Expense, refer to Section 9 – Service Entrance Section Lock Box & Seals. SRP reserves the right to decide if this type of arrangement is acceptable.
- E. Areas that require 24-hour SRP access and are behind electronically controlled gates are required to install an SRP restricted access switch assembly at the Customer's Expense (see Section 1 – XIV. Access to Service Entrance Section/Metering on Customer's Premises).
- F. A Master Meter Service is available for new commercial and multi-level residential projects where SRP's billing meters cannot be located on the ground floor or one level below the ground floor, provided this is not the lowest level of the Building.

2. Unacceptable SES Locations

Both the Customer and SRP share an interest in the location of the SES for reading, testing, repairing, replacing and emergency purposes. The following is a partial list of unacceptable SES locations:

- In locations that are not Readily Accessible (see Glossary, Readily Accessible).
- Within substations or transformer vaults containing SRP transformers and equipment.
- In locations hazardous to personnel.
- On surfaces subject to excessive vibration. (Example: trash enclosure walls)
- Inside rest, bath, shower, powder or toilet rooms.
- In an unsanitary area in reference to farm animals and products.
- On SRP poles or other SRP facilities.
- Within 20 feet of any fuel pump or any fuel storage tank (refer to Section 5 – Overhead/Underground Above-Ground Storage Tanks Containing Volatile Flammable Liquids NESC Rule 127 and Section 5 – Underground Clearances Fuel Storage Dispensing).

EXCEPTION: 10' from self-contained diesel facilities.

- Within 36" of any natural Gas meter vent.

 <p>Electric Service Specifications SRP[®] PROPRIETARY MATERIAL</p>	REV: Revised Note 1.B	
	METERING & SES EQUIPMENT / METER ROOMS	ISSUE DATE: 04/15/86 REV. DATE: 07/23/25 APPROVAL: J. Robbins
9-1-1		ESS9-1-1.doc

- Within parking structure.
EXCEPTION: Customer-Owned Service, refer to Section 3 – General Information for Underground Installation.
- Residential SES units shall not be behind wall.
- Within 5' from the edge of a drivable path.
- Elevated platforms not meeting allowances specified in Section 9 – Switchboards, General Information

3. SRP Meter Room Requirements in Addition to AHJ Requirements

Meter rooms are not preferred by SRP. However, if the Customer desires this type of construction, the following requirements are mandatory to ensure the safety of SRP personnel and equipment.

- A. A meter room is a dedicated, illuminated room on the ground floor, accessible from the outside. Meter rooms are provided and maintained by the Customer for the Customer’s electric Service Equipment only.
- B. The meter room shall be Readily Accessible. Direct (without bends) unobstructed access to any meter room entrance shall be provided and maintained by the Customer at all times. This access shall be suitable for Line construction equipment and shall be a minimum 12 feet wide and 16 feet high along the entire route. A bend in the access route is allowed if the width is increased to 20 feet. Due to obstructions which jeopardize access and safety, meter rooms are not permitted to be located on or in loading dock areas.

The meter room shall be totally isolated from the rest of the Building by not less than a one-hour fire-rated boundary for all interior walls, floors, ceilings, doors and any interior wall penetrations of the meter room boundary. Exterior walls and penetrations of the meter room shall be subject to the local AHJ fire rating requirements. Roll-up doors, glass doors and windows are not permitted.

- C. The number of entrance doors is dictated by NEC 110.26 and number of pull sections. All entrance doors to the meter room from the access area described in III.B shall be through a standard doorway opening (minimum 32" x 6 1/2' high). The centerline of the pull section shall be in line with the door opening. For meter rooms with multiple pull sections, a separate doorway shall be required for each pull section. The path away from the SES to each exit shall be continuous and unobstructed.
- D. A second doorway shall adhere to the following requirements:
 - 1) If a second entrance door is required by NEC 110.26, it shall open to the outside of the Building.
EXCEPTION: The second doorway may open to areas continuously accessible to the general public (see Glossary, General Public Area), without travel through restricted or secured areas. This door shall have a minimum fire rating of one hour.
- E. The Customer may request an additional doorway for an entrance from the Building interior; this doorway is not required by NEC 110.26 but may be used as an entrance to the meter room by Customer personnel only. The door shall have a minimum fire rating of one hour, automatically lock when shut and not allow SRP personnel access to the Building interior. Door shall not be equipped with panic hardware. Signage clearly stating “not an exit” shall be placed on the door. All entrance doors used as an entrance and exit by SRP personnel shall swing out and be equipped with panic hardware.

	REV: Revised Note 1.B	
	METERING & SES EQUIPMENT / METER ROOMS	
	ISSUE DATE: 04/15/86 REV. DATE: 07/23/25 APPROVAL: J. Robbins	
	9-1-2	ESS9-1-1.doc

F. Meter Room Door Signage Requirements

- 1) Material: Metal.
- 2) Color: Red letters on white background.
- 3) Verbiage: "Electric Equipment Room" and "Danger – High Voltage Inside".
- 4) Letters: Block, three quarters of an inch minimum.
- 5) Attachment: Permanently affixed to outside of exterior door with threaded fasteners or rivets (no painting), attachment height of five feet +/- six inches.
- 6) Meter rooms with alarmed doors must have signage for 24-hour contacts.

G. When the meter room is ventilated, it shall be ventilated directly to the outside, without using flues or ducts. If ducts are required, they shall be completely isolated from air ducts serving other parts of the Building and constructed of fire resistant materials.

H. Supply air duct runs shall dead-end into the meter room. The mechanical unit supplying air to the meter room may serve other parts of the Building, provided ventilation openings to the meter room have automatic closing fire dampers rated at not less than one hour.

I. External ventilation openings from the meter room shall be located as far as possible from doors (excluding the exterior meter room door), windows, fire escapes and combustible material. Where a mechanical ventilation unit is dedicated solely to the meter room, fire dampers are not required.

J. No piping, ducts or equipment foreign to the electric Service Equipment or architectural appurtenances shall be permitted to be installed in or pass through the meter room. If space requirements for the electrical SES equipment are not impaired, the following equipment may be allowed in the meter room:

- 1) Distribution and branch electrical panels.
- 2) Communications equipment.
- 3) Alarm systems.
- 4) Small, dry-type transformers used to provide auxiliary voltage.
- 5) Sprinkler heads and the branch water line supplying the sprinklers inside the room. Water lines or sprinkler heads shall not be directly located over the SES.

K. The meter room shall not be used for storage. The working space must be clear and unobstructed at all times.

L. NEMA 3R enclosures are not required in a meter room. The centerline of the meter shall be between three feet and six feet three inches from floor level. The workspace around the SES shall be level and the same elevation as the SES pad. Housekeeping pads are not allowed (raised pad, not level with floor).

EXCEPTION: NEMA 1-rated enclosures may be installed in a meter room on a housekeeping pad, provided the pad does not extend beyond the SES dimensions.

M. Electrical equipment with hinged doors or panels shall be positioned in the room to provide a minimum 24" direct egress path with the doors open in any position.

 <p>Electric Service Specifications PROPRIETARY MATERIAL</p>	REV: Revised Note 1.B	
	METERING & SES EQUIPMENT / METER ROOMS	ISSUE DATE: 04/15/86 REV. DATE: 07/23/25 APPROVAL: J. Robbins
	9-1-3	ESS9-1-1.doc

4. Meter Rooms Containing Metering Equipment over 600 V

Refer to Section 9 – High Voltage Metering Enclosure, 4-Wire, 2,400-12,470 Volt Service.

The following requirements are in addition to the meter room requirements listed above.

- A. A 12' clear and level work space shall be maintained in front of the pull section of the metering cabinet. In addition, an exterior entrance door used for cable installation shall be located directly in front of the pull section and directed to the exterior of the room.

EXCEPTION: If the 12' clear work space cannot be maintained between the meter cabinet and exterior wall, the entrance doorway shall be increased to 6' wide in order to extend the work space beyond the exterior of the Building.

- B. An 8' clear work space shall be maintained in front of the utility voltage transformer (VT) compartment of the metering cabinet. Entrance into this work space may be through the doorway required above. However, the path away from this compartment to the exit shall be straight, continuous, and unobstructed.

5. Screen walls and Enclosures for Commercial SES Equipment

A screen wall or enclosure surrounding any commercial SES shall meet the following requirements.

- A. Vehicle access to the SES, refer to Section 5 – Vehicle Access Requirement, Pad-mounted Facilities & 1Ø Transformers.
- B. SES access, exit and clearance requirements including doors and signage shall adhere to the rules for meter rooms.

EXCEPTION: Gates and/or openings are permitted provided the number, placement and size meet the meter room requirements for entrance doors. A gate shall include a stop to allow it to be locked open in any position. Gates shall open a minimum of 180 degrees with no obstructions and will not impede safety of personnel, emergency access or public traffic.

 <p>Electric Service Specifications PROPRIETARY MATERIAL</p>	REV: Revised Note 1.B	
	METERING & SES EQUIPMENT / METER ROOMS	ISSUE DATE: 04/15/86 REV. DATE: 07/23/25 APPROVAL: J. Robbins
	9-1-4	ESS9-1-1.doc

EQUIPMENT ROOM EXAMPLES
Equipment Rooms with One Entrance

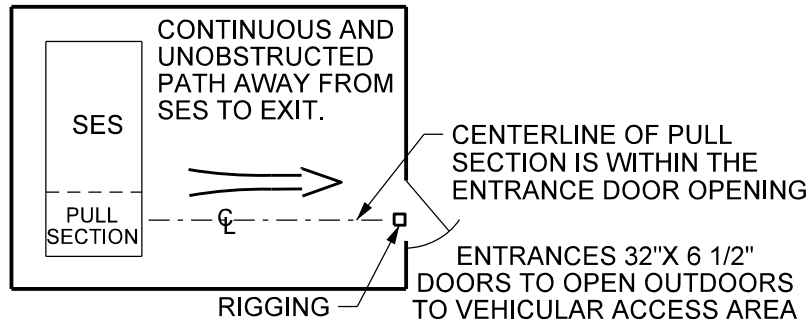

Equipment Rooms with Two Entrances
 NOTE 3

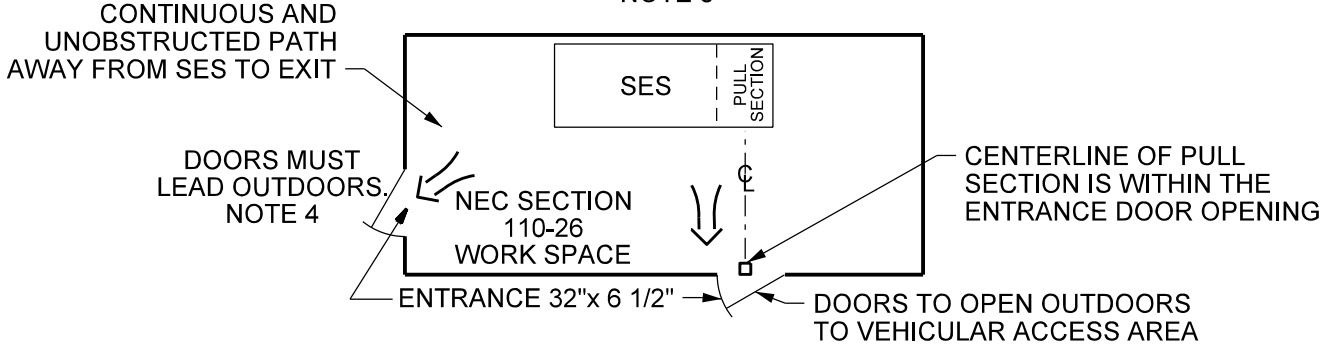

Equipment Room Readily Accessible for SRP Vehicle Access.

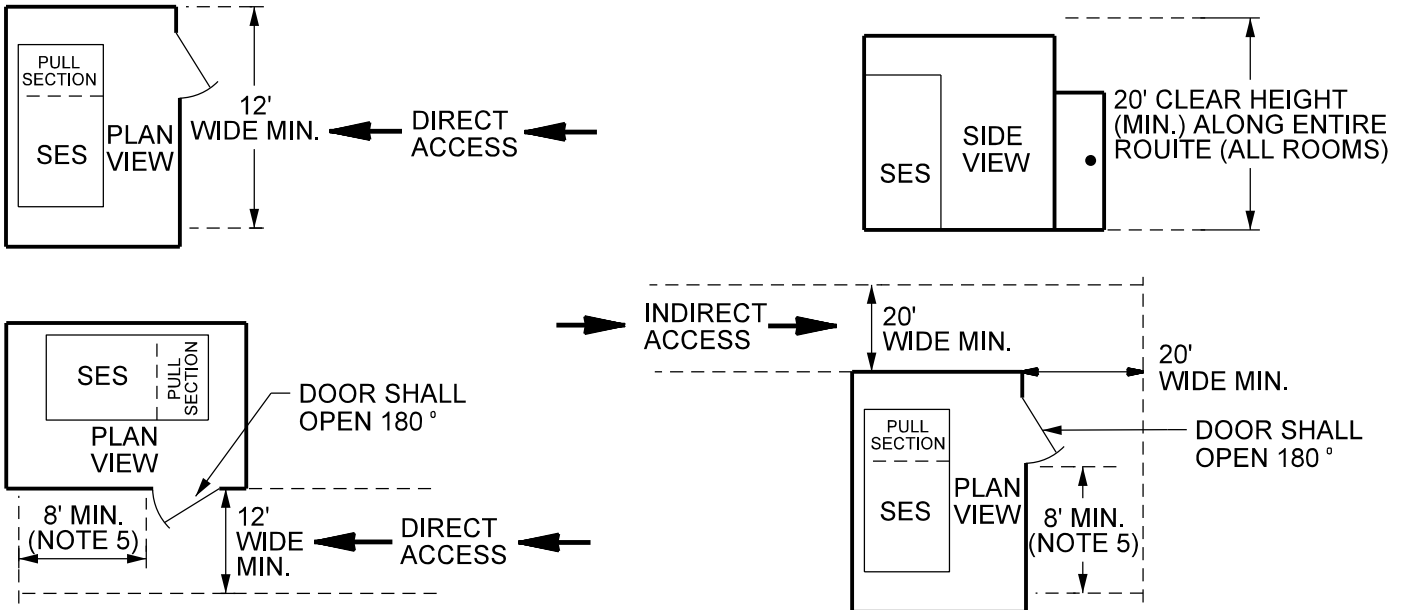

NOTES

1. SRP meter room requirements, refer to Section 9 - Equipment / Meter Rooms.
2. See NEC Article 110-26 for working space and entrance requirements.
3. NEC 110.26 requires a second entrance for a SES rated 1,200 A or more and over 6' wide. EXEPTION: A single entrance is permitted where there is a clear and unobstructed path to exit or the depth of the working space is doubled.
4. For an entrance door not required by NEC110.26, door may open indoors, shall not be accessible by SRP personnel, and shall have signage clearly indicating "NOT AN EXIT".
5. Minimum 8 feet clear space for backing and positioning beyond the equipment.

	REV: Add Note 5 for additional information	ISSUE DATE: 04/20/10
	METERING & SES EQUIPMENT / METER ROOMS	REV. DATE: 11/05/25
	9-1-5	APPROVAL: J. Robbins
		8509E312.DGN

**SERVICE ENTRANCE SECTION (SES)
EQUIPMENT / METER ROOMS ALTERNATIVE**

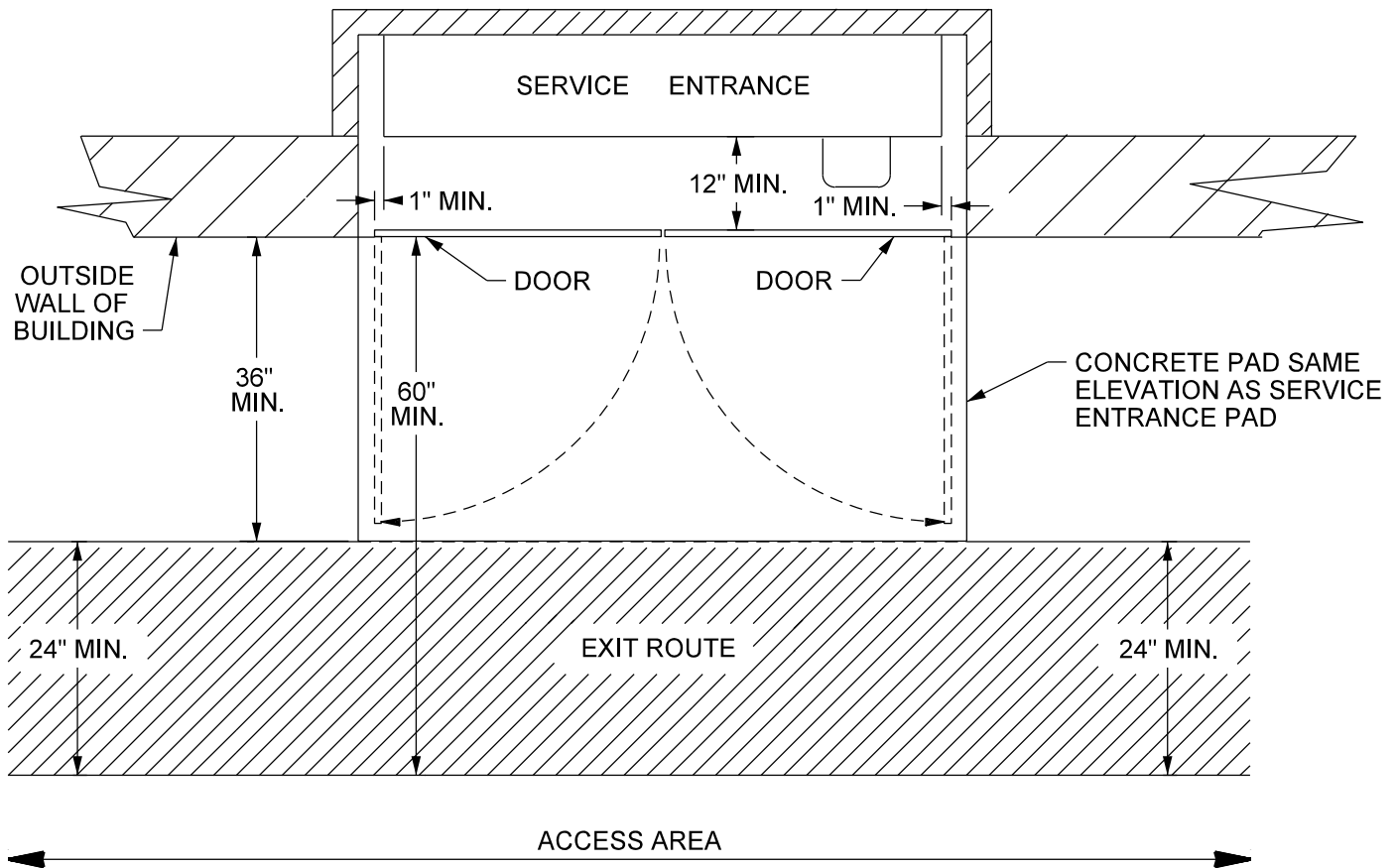

NOTES

6. When rear access is not required, the following alternative to a SES equipment room is acceptable: (only for service sections 90" high):
 - A. All hinged doors (including meter door), when open, may not block exit route. When doors are open at 90° (typical full open), exit shall be 24" minimum.
 - B. The door(s) shall have a multiple hasp for installation of an SRP Customer lock. Refer to Door Security note in Section 9 - Service Entrance Section Lock Box & Seals.
 - C. Door(s) to open beyond the full width of service entrance by at least 1" on each side. Door(s) shall be metal and shall lock open at 90°.
 - D. Refer to Meter Room Door Signage Requirements note in Section 9 - Service Entrance Section Equipment / Meter Rooms.
 - E. The SES must face and be readily accessible from the outside of the building. This area to be kept clear and accessible at all times.
 - F. Ceiling and interior doors and walls to carry a one-hour fire rating.
 - G. Area adjacent to SES shall comply with Note 3B of Section 9 - Service Entrance Section Equipment / Meter Rooms.

 PROPRIETARY MATERIAL	REV: Updated note F to indicate interior doors and walls only	ISSUE DATE: 04/15/86
	METERING & SES EQUIPMENT/METER ROOMS ALTERNATIVE	REV. DATE: 03/22/18
	9-1-6	APPROVAL: N. Sabbah
		8509E42.DGN

7. Door Security

- A. The door to the meter room must be locked. It shall be by one of the following:
- 1) A double hasp arrangement that will accommodate both an SRP lock and Customer lock.
 - 2) A locking mechanism built into the door (see I.B)
 - 3) Where there is a need for a high level of security (i.e., banks), the Customer may make a special request to have SRP install a high-security locking mechanism in the door, at the Customer's expense. This lock will be keyed to allow SRP and the Customer access to the meter room (see I.B).
- B. For 7.A, 1 and 2, the Customer shall be responsible for providing and installing a lock box on or within 36" of the door. The Customer shall furnish a key to the meter room and place it in the lock box. The key must not unlock any other door on premises. See ESS Section 11 – Meter Room Lock Box.

8. Seals

- A. All removable panels and access covers to compartments used for terminating or routing un-metered conductors shall be sealed by SRP. When a raceway or conduit for meter secondary wiring is necessary, such a raceway or conduit shall be sealed by SRP. Do not locate removable panels or covers requiring sealing behind other panels, covers or doors (except rain-tight enclosure doors).
- B. Hinged cover panels shall be sealed on the side opposite the hinges.
- C. Removable cover panels and access covers shall be sealed with stud and wing nut assemblies on opposite sides of the panel or cover.
- D. Alternate sealing methods may be used if the removable covers are self-supporting with the captive screws and sealing provisions removed.
- E. Sealing and securing devices shall be provided by the Customer as follows:
- 1) Stud and wing nut assemblies shall consist of a 1/4 x 20" (minimum) stud and an associated wing nut, each drilled a minimum of 0.0635 inches for sealing purposes. Attach stud securely so that it will not loosen or screw out when being fastened.
 - 2) Sealing screws shall be drilled a minimum of 0.0635 inches for sealing purposes.
- F. All securing screws shall be captive.
- G. Screws or bolts requiring special tools for installation or removal are not acceptable.
- H. All cover panels intended to be permanent and not requiring future removal for access (top and sides) shall be secured in place with fasteners that cannot be loosened or removed from the outside.
- I. Latching devices shall be designed to permit positive locking and be made of durable corrosion resistant material.
- J. All service switches or breakers shall have provisions for sealing in the open position.

	REV: Updated verbiage under 1.B.	
	METERING & SES SERVICE ENTRANCE SECTION (SES) LOCK BOX & SEALS	ISSUE DATE: 01/06/05 REV. DATE: 08/08/23 APPROVAL: C. O'Brien
	9-1-7	ESS9-1-7.doc

SERVICE DISCONNECT REQUIREMENTS

1. GENERAL

- A. Service disconnect(s) shall disconnect all ungrounded service conductors from a building or other structure.
- B. Service disconnect(s) are furnished, installed, and maintained by the customer. Installations shall be approved by the Authority Having Jurisdiction (AHJ). SRP reviews compatibility with the source side bus (including interrupting rating).
- C. Service disconnect(s) shall be in, or immediately adjacent to the SES equipment.
- D. Each service disconnect shall be permanently marked to identify it as a service disconnect.
- E. The maximum number of service disconnects is six.
- F. Service disconnects(s) shall be installed prior to SRP installing a meter.
- G. When a hipot test is required by the AHJ, all service cables including metering must be isolated from the SES by SRP, which may require fees.

2. METER AND SERVICE DISCONNECT INSTALLATION

A. Single Service w/ Single Meter

- 1) A single service disconnect located on load side of the meter socket.

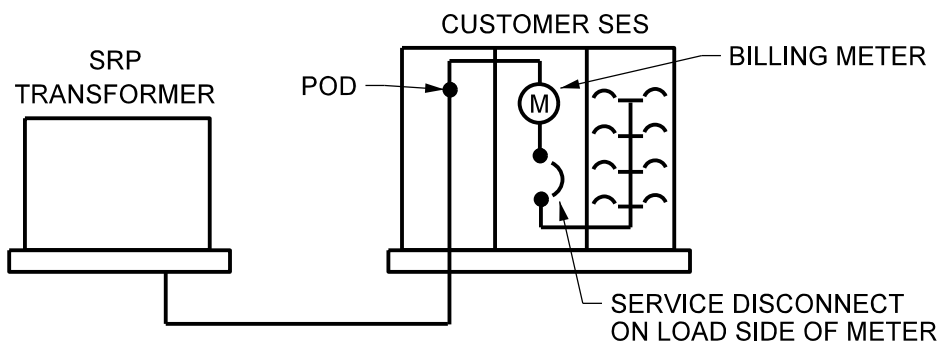

- 2) Multiple service disconnects (not more than 6) located on the load side of the meter socket.

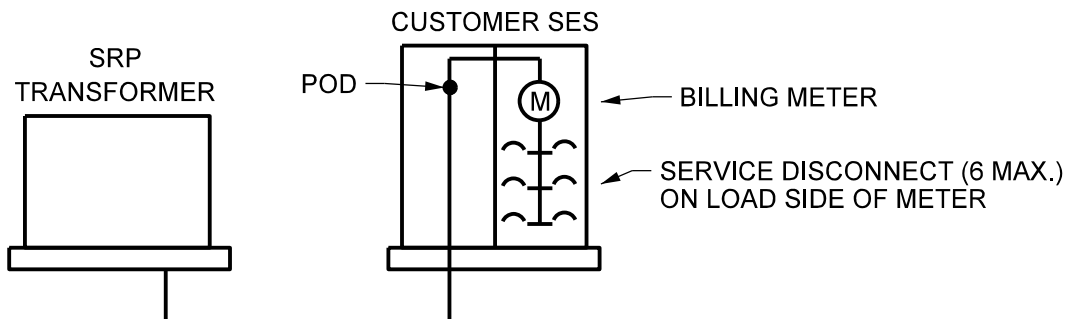

Electric Service Specifications  PROPRIETARY MATERIAL	REV: Added new sections and details	ISSUE DATE: 11/15/12
	METERING & SES SERVICE DISCONNECT REQUIREMENTS	REV. DATE: 08/13/21
	9-2-1	APPROVAL: K. MacFadyen
		8509E351.DGN

B. Single Service w/ Multiple Grouped Meters

1) TWO TO SIX METERS

a) Individual service disconnects (not more than 6) on the load side of each meter socket.

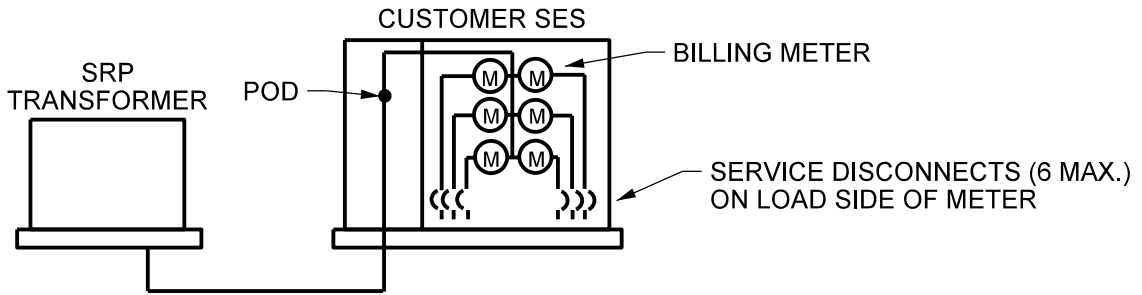

b) A single main service disconnect located directly after the point of delivery (POD), ahead of the meter sockets and individual service disconnects.

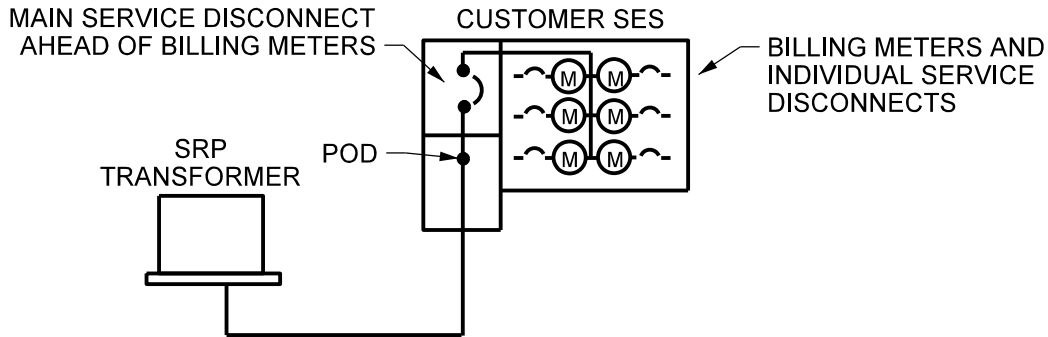

2) SEVEN OR MORE METERS - A single main service disconnect located directly after the POD ahead of the meter sockets and individual disconnects.

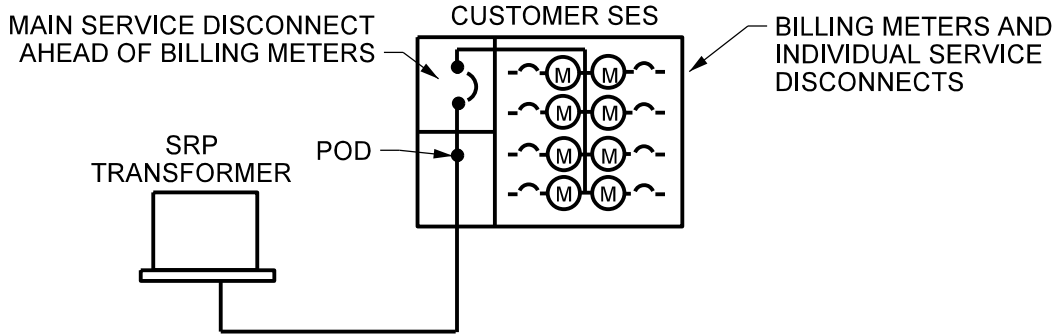

<p>Electric Service Specifications</p>  <p>PROPRIETARY MATERIAL</p>	<p>REV: Added new sections and details</p>	<p>ISSUE DATE: 11/15/12</p>
	<p>METERING & SES SERVICE DISCONNECT REQUIREMENTS</p>	<p>REV. DATE: 08/13/21</p> <p>APPROVAL: K. MacFadyen</p>
<p>9-2-2</p>		<p>8509E410.DGN</p>

EXCEPTION:

- a) Where the bus splits after the POD at the SES, each bus may have a single disconnect ahead of the meter sockets, individual disconnects on the load side of each meter in a group, or a combination of both not to exceed six service disconnects.
- b) A placard one-line diagram of the SES identifying each service disconnect shall be placed on the SES pull section.

Example placard (for reference only):

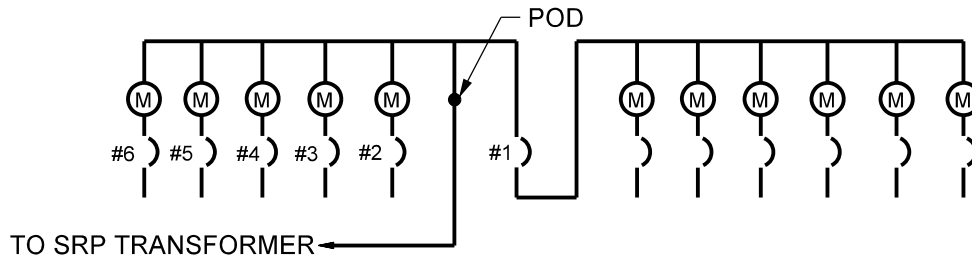

3. METER DISCONNECTS & LOCKING PROVISIONS

- A. Meter disconnects supplied from instrument transformer compartments shall be capable of being locked in the open (off) position.
- B. Locking provisions may be:
 - 1) A lockout device which is incorporated as an integral part of each meter disconnect.
 - 2) A lockable cover for each meter disconnect where the lock prevents the operation of the disconnect and prevents removal of the cover.
 - 3) A lockable cover for multiple meter disconnects where the lock prevents the operation of any of the disconnects, prevents removal of the cover, and all disconnects are supplied from a single instrument transformer compartment.
 - 4) Items B1, B2 and B3 may have provisions to accept two locking devices.
 - 5) For fused disconnects, the fuse access cover shall be lockable when the disconnect is locked in the off (open) position.
 - 6) All locking provisions for disconnects rated less than 400 amps shall accept a lock shank of not less than 1/4".
 - 7) All locking provisions for disconnects rated 400 amps and above shall accept a lock shank of not less than 5/16".

	REV: Added new sections and details	
	METERING & SES SERVICE DISCONNECT REQUIREMENTS	ISSUE DATE: 11/15/12
		REV. DATE: 08/13/21
		APPROVAL: K. MacFadyen
	9-2-3	8509E411.DGN

1. Addressing - Job Location

- A. The assignment of street addresses is performed according to the policies and regulations adopted by the MAG or AHJ.
- B. Any variance from the addresses assigned by the municipality may delay the energizing of electrical service. Clearances are dispatched to SRP using the originally assigned address, apartment number, suite number, etc. SRP will only accept numeric designations (e.g., 3rd) and will not accept spelled-out numbers (e.g., third).
- C. The Customer shall provide SRP with the assigned address corresponding to the job location when applying for electric service. This address, including the lot number if applicable, shall be posted at the job site in a location visible from the street or road fronting the property to assist SRP personnel.
- D. Unless otherwise specified by MAG or AHJ, address characters shall be a minimum 2" height and width.

2. SES Identification and Permanent Labels:

SES's are identified using labels to indicate the address and corresponding units they serve. Establishment of service will be delayed until labels are installed correctly and complete.

- A. Labels shall be made of metal and installed as specified in Section 11 - Customer-Supplied Material - Labeling, SES.
- B. Single-family dwelling with a single meter, a permanent address shall be posted on the dwelling in accordance with AHJ or MAG, or a metal address label be affixed to the meter cover panel.

EXCEPTION: SES used for early power shall have a label affixed to the meter cover panel.

Single-family dwelling with multiple services and/or more than one utility meter, an address label shall be affixed to the meter socket panel for each meter location. Each address label shall have a unique identifier assigned by a SRP Customer Service Representative for each separate metered service. Additionally, the AHJ may impose further labeling requirements in accordance with NEC 230.2.

- C. Multi-family dwelling, including but not limited to apartments, condos, and town-homes, shall have their electrical connection between the meter socket and the unit's electrical panel verified by SRP. To assist with this effort, metal labels shall be installed as follows:
 - 1) Meter socket panel. If the main breakers are not directly adjacent to the meter, both the meter and the main breaker shall be identified with individual matching labels.
 - 2) Sub-panel dead-front. The label shall display the unit number that matches the corresponding wiring to the associated meter.
 - 3) Door or Door jamb. A temporary label is allowed at time of verification and meter install. Upon completion of service, matching permanent address label shall be affixed at the unit's entrance that is in accordance with MAG or AHJ. Access to dwellings shall be provided by the Customer or an authorized contractor to allow SRP personnel to perform their duties.
- D. Pull sections with multiple meters attached to building wall: Address shall be attached to the exterior of the pull section panel not removable by the Customer (sealed panel). Unit number shall be attached to the exterior of a panel not removable by the Customer (sealed panel) directly adjacent to each meter and repeated at each corresponding main breaker.

 <p>Electric Service Specifications</p> <p>PROPRIETARY MATERIAL</p>	REV: Align address requirements with MAG/AHJ, new label requirements for single and multi-family	
	<p>METERING & SES</p> <p>ADDRESSING & IDENTIFICATION</p>	<p>ISSUE DATE: 04/15/86</p> <p>REV. DATE: 04/22/25</p> <p>APPROVAL: J. Robbins</p>
	9-3-1	ESS9-3-1.doc

- E. Enclosed SES: Address shall be attached to the exterior door of the SES, unit number shall be attached to the interior of a panel not removable by the Customer (sealed panel) directly adjacent to each meter and repeated at each corresponding main breaker
- F. Pedestals or Meters Mounted on Equipment Structure: a label containing the address and unit number (where required) shall be affixed to a sealed exterior panel that cannot be removed by the Customer. It shall be positioned directly next to each meter and repeated for each corresponding main breaker. See Section 11 - Customer-Supplied Material - Labeling, SES, Meter Cover Panel.

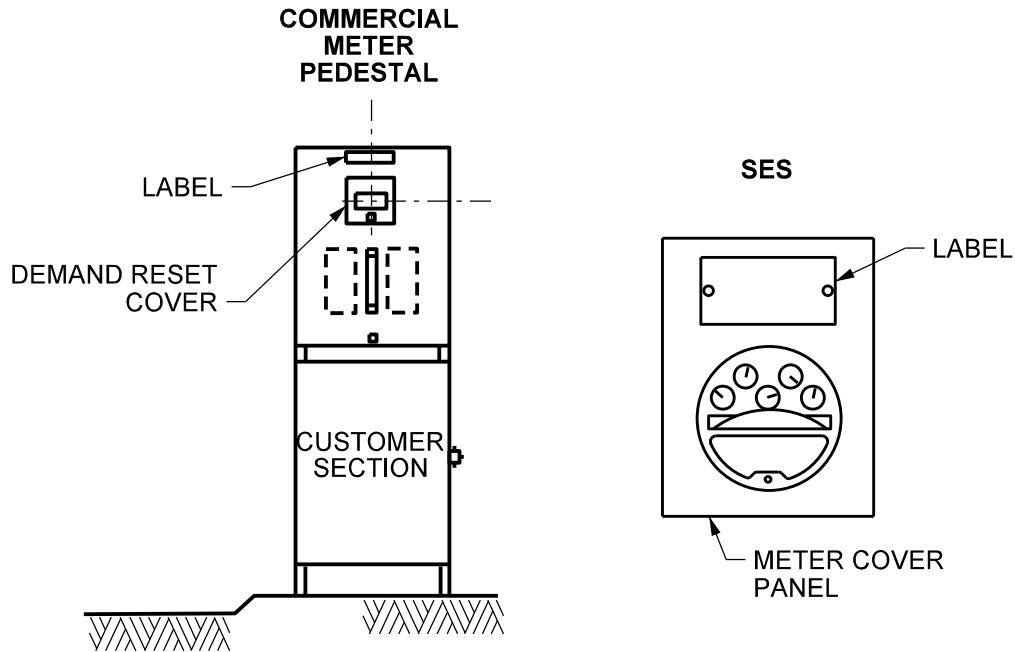

- G. Multiple Buildings: a label with building or unit number and street address shall be affixed to the pull section. See Section 11 - Customer-Supplied Material - Labeling, SES, Pull Section, Multiple Buildings.

SERVICE ENTRANCE SECTION

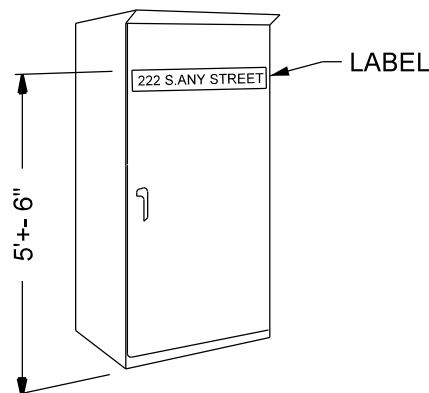

<p>Electric Service Specifications</p>  <p>PROPRIETARY MATERIAL</p>	REV: Update language for clarity and added references to Section 11	
	<p>METERING & SES ADDRESSING & IDENTIFICATION</p>	
	9-3-2	<p>ISSUE DATE: 04/15/86</p> <p>REV. DATE: 06/04/24</p> <p>APPROVAL: J. Robbins</p> <p>8509E125.DGN</p>

1. Ratings

All meter sockets shall be UL-approved, with accepted nominal ratings as follows:

- A. 100 amps
- B. 200 amps
- C. 400 amps (Class 320) – Residential services only, 320 amps max.

2. Test Block (Safety Sockets) Application:

Test blocks (safety sockets) are required or exempt based on service type and operational needs. Operational needs refer to whether meter work can be performed without causing an unacceptable outage.

- A. **General (Non-Residential) Services:** Test blocks shall be installed on all non-residential services rated 200 amps or less.
- B. **EXCEPTIONS:** Test blocks are not required for the following service types:
 - 1) **Structures on Residentially Zoned Lots Not Used for Business Purposes (320 amps or less):** Test blocks are not required where temporary outages for operation and maintenance are deemed acceptable. This includes non-residential structures not limited to (i.e. garages, barns, shops).
 - 2) **Temporary Services (200 amps or less at 240 V single-phase)**

For the exceptions listed below, panel schedules shall be submitted to SRP Design for review prior to installation.

 - 3) **Non-Critical Loads (30 amps or less at 120 V):** Includes, but is not limited to: sprinkler controllers, landscape lighting, barns, corrals, water features, approved small cell sites.
 - 4) **DER Non-Billing Production Meter (200 amps or less at 240 V single-phase)**

3. Terminals for Service Entrance Conductors

Meter sockets shall be provided with terminals suitable for the service entrance conductors.

SRP gives no warranty, expressed or implied, as to the adequacy, safety or other characteristic of any equipment, wiring or device, and assumes no responsibility with respect thereto.

4. Automatic Meter Sockets

Meter socket shall not be equipped with circuit-closing or bypass devices that automatically close when the meter is removed from the socket.

 <p>Electric Service Specifications PROPRIETARY MATERIAL</p>	REV: Clarified rating and application requirements. Reloc. definitions to Glossary	
	<p>METERING & SES SELF-CONTAINED METER SOCKETS</p>	<p>ISSUE DATE: 04/15/86 REV. DATE: 05/15/26 APPROVAL: J. Robbins</p>
	9-4-1	ESS9-4-1.doc

5. Self-Contained Meter Sockets Arrangements

The following arrangements identifies clips and positions for self-contained meter sockets.

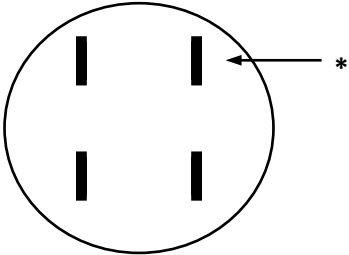
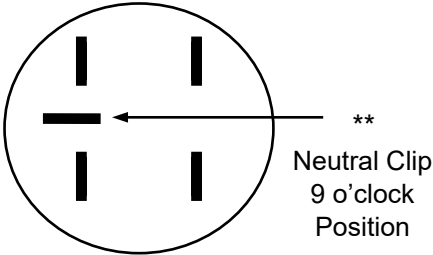
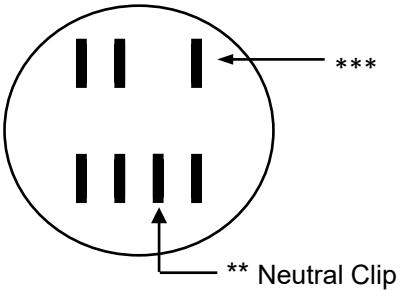
TYPE OF SERVICE	SOCKET TYPE
Meter Form 1s 1Ø, 2-wire, 120V* Meter Form 2s 1Ø, 3-wire, 120/240V 1Ø, 3-wire, 240/480V	4 Clip 
Meter Form 12s 1Ø, 3-wire, 120/208V	5 Clip 
Meter Form 16s 3Ø, 4-wire, 120/240V (replaces 15s) 3Ø, 4-wire, 120/208V 3Ø, 4-wire, 277/480V	7 Clip 

* Neutral must be on top right side, 1Ø, 2-wire, 120V (SRP will install neutral jumper).

** Connect to neutral terminal with #12 copper wire, white in color.

*** For all self-contained meter sockets, the power leg shall always be in the right-hand terminal position (C phase) and must be permanently identified in blue with an orange tracer at all termination points.

NOTES

1. See Section 1 – Character of Service and Limitations for approved service classifications.

	REV: Clarified rating and application requirements. Reloc. definitions to Glossary	
	METERING & SES SELF-CONTAINED METER SOCKETS	ISSUE DATE: 04/15/86 REV. DATE: 05/15/26 APPROVAL: J. Robbins
9-4-2		ESS9-4-1.doc

6. Current Transformer Rated Meter Socket Arrangements

The following arrangement identifies clips and positions for current transformer meter sockets.

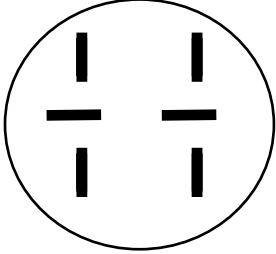
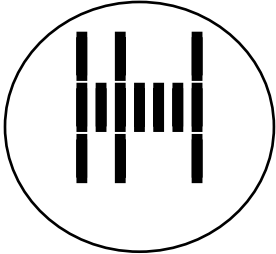
TYPE OF SERVICE	SOCKET TYPE
Meter Form 4s 1Ø, 3-wire, 120/240V	6 Clip 
Meter Form 9s 3Ø, 4-wire, 120/240V delta* (replaces 8s) 3Ø, 4-wire, 120/208V 3Ø, 4-wire, 277/480V 3Ø, 4-wire, 2,400/4,160 V 3Ø, 4-wire, 7,200/12,470 V A 15 meter clip base is acceptable utilizing the 13 clips shown.	13 Clip 

* For CT-rated meters, the center terminal position (B phase) can be a wild leg (yellow with orange tracer).

NOTES

1. See Section 1 – Character of Service and Limitations for approved service classifications.
2. When current transformer rated sockets are installed on panels, they shall be fabricated and installed by the manufacturer for back connection

	REV: 9-4-1 when safety Test Block Not Required	
	METERING & SES CURRENT TRANSFORMER METER SOCKETS	ISSUE DATE: 04/15/86 REV. DATE: 04/07/21 APPROVAL: V. Bevins
9-4-3		ESS9-4-3.doc

1. Customer Furnishes, Installs and Maintains

- A. Self-contained meter sockets.
- B. Multiple meter panels and pre-fabricated panels.
- C. Meter enclosures and their identification.
- D. Metering transformer cabinets and switchboard devices.
- E. Perches – for safety test switches when required.
- F. Safety test blocks for self-contained meters.
- G. Landing lugs as specified by SRP.
- H. Meter sockets for instrument transformer meters (refer to Section 9 – Current Transformer Meter Sockets).
- I. SRP will furnish and install the normal secondary wiring from the instrument transformer to the meter socket.

2. SRP Owns, Furnishes, Installs and Maintains

- A. All meters required for billing purposes.
- B. Sealing rings and seals.
- C. Test switches for instrument-rated transformers.
- D. Instrument transformers.

3. Connections by SRP

- A. Metering shall be connected in the service entrance conductors on the line side of the Customer’s load.
- B. SRP makes all final connections to the meters (refer to notes 4, 5, and 13 of Section 9 – Terminating Facilities Underground Pull Boxes or Pull Sections).
- C. SRP connects the secondary wiring in the meter sockets used with transformer-rated meters.
- D. Data Pulse Initiators are available upon request.

4. Equipment Openings by Customer

For routing conductors in or out of service entrance equipment, an approved method shall be used. The burning of holes in the equipment or the welding of couplings or fitting in lieu of an approved hub will not be accepted.

5. Customer Devices

Customer devices installed with a Supply-Side Source Connection shall be located at the service entrance section, after the billing meter and before the source side of the service disconnect, outside of any sealed area. When modifying a SES and its components, and prior to re-energization, an electrical clearance from the AHJ is required. Such installations shall comply with NEC Rule 230-82, UL 891, and the following:

- A. Labeled equipment shall not be modified unless done with a manufacturer’s labeled retrofit kit, or the modification is certified by a qualified third party.

	REV: Verbiage updates under 5. Customer Devices	
	METERING & SES EQUIPMENT RESPONSIBILITY	ISSUE DATE: 04/15/86 REV. DATE: 07/05/22 APPROVAL: J. Luera
	9-5-1	ESS9-5-1.doc

- B. Approved methods for protection of conductors:
 - 1) Above ground: RMC, IMC, or approved fiberglass
 - 2) Below ground: PVC
- C. Conductor/connector ampacity rating shall be determined using a minimum ambient temperature of 110 degree F.
- D. The short-circuit current rating of any disconnect or over-current protection device is equal to or greater than the service equipment.
- E. Use a captive flat-blade screw fastener on any hinged access door (no cover plates).
- F. Affix a permanent label located at the main or each service disconnect that states:
 "WARNING: This main disconnect does not disconnect control power to *insert equipment name*. The *insert equipment name* disconnect is located in *insert location name*."
 EXAMPLE: See ESS Section 11 – Customer-Supplied Material: Disconnect Warning Sign.
- G. Affix a permanent label, located on any door that provides access to the control power circuit disconnect, that states:
 "WARNING: Control – Instrument circuit disconnect located behind this door. The line side of this disconnect remains energized when main disconnect located in service entrance section is in open/off position."
- H. SRP recommends tap connections be made with a mole bar assembly connector (e.g., Utilco, Homac, Polaris or equivalent) designed and rated for this application. Insulation piercing connections or taps that cannot be inspected without removing insulation are not recommended. AHJ has final say.
 NOTE: Interconnected electric power production sources must have a signed contract and comply with SRP "Interconnection Requirements".
 Log onto srpnet.com/electric/generators.aspx for more information about interconnection of generation.

6. Equipment Mountings

Devices furnished and installed by the Customer shall be securely attached to a supporting structure.

 <p>Electric Service Specifications SRP[®] PROPRIETARY MATERIAL</p>	REV: Verbiage updates under 5. Customer Devices	
	METERING & SES EQUIPMENT RESPONSIBILITY	ISSUE DATE: 04/15/86 REV. DATE: 07/05/22 APPROVAL: J. Luera
	9-5-2	ESS9-5-1.doc

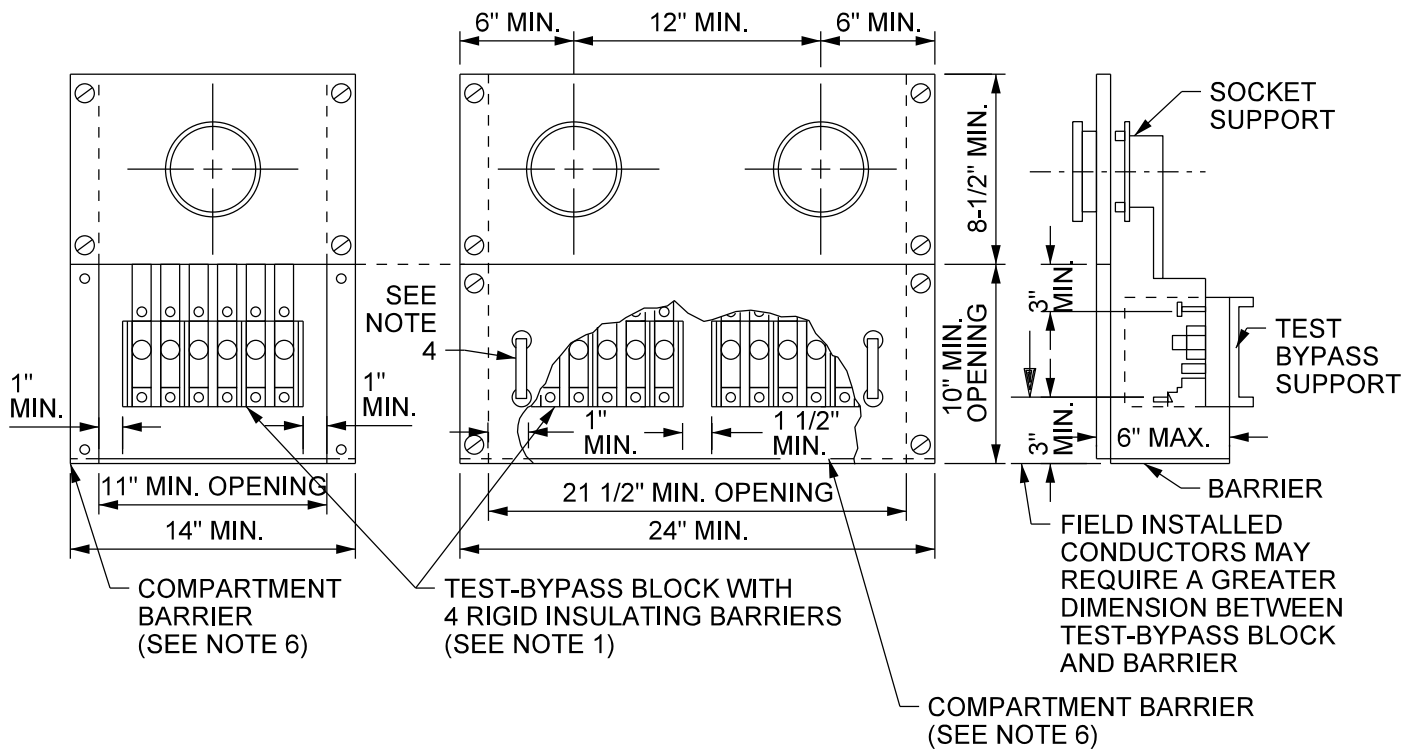

NOTES (Reference EUSERC Drawing 306)

1. Test-bypass blocks with rigid insulating barriers shall be furnished, installed and wired or bussed to the meter socket by the manufacturer. Connection sequence is line-load from left to right.
2. Metered conductors shall not pass through adjacent metering compartments except in enclosed wireway. To ensure proper identification of cables in factory cabled equipment, metered cables (except in the test-bypass area), shall be either physically barriered or bundled so as to separate them from unmetered cable, or permanently marked and isolated from unmetered cables. Physical barriers will not be required if the unmetered conductors are bus.
3. Meter panels shall be removable with a maximum of two meters per panel.
4. Test-bypass block cover panel shall be sealable and fitted with a lifting handle. All panels exceeding 16" in width shall require two lifting handles.
5. An insulated neutral terminal shall be provided behind each test-bypass cover panel. The terminal shall be readily accessible when the cover panel is removed and shall be individually connected to the neutral bus with a minimum size No. 8 copper wire.
6. Barrier shall:
 - A) consist of an insulating non-tracking material resistant to ARC tracking.
 - B) be secured in place and rigid, with maximum deflection of 1/2" (from an applied downward force of 25 lbs.).
 - C) be dimensioned to fit the switchboard, with a peripheral gap not to exceed 3/8".
 - D) contain cutouts for through bus bars that provide a maximum gap between bus and barrier of 3/8".
 - E) not exceed ventilation hole diameter of 3/8" when provided.
7. For 3Ø, 4-wire, connect 7th jaw to body of neutral lug with No.12 minimum copper wire, white in color.
8. For 3Ø, 4-wire delta, identify right-hand test-bypass block (2 poles) as power leg. I.D. color: blue with orange tracer.
9. For 1Ø, 3-wire, omit center test-bypass block.
10. For 1Ø, 3-wire, 120-208 volts, omit center test-bypass block and connect 5th jaw to body of neutral lug with No. 12 minimum copper wire, white in color.
11. Meter panels shall be removable but shall be non-removable when meter is in place. Meter socket is to be supported independent of and attached to meter panel.
12. Contractor or manufacturer shall install separate line and load conductors for each meter socket.
13. Each line and load position shall be clearly identified by 3/4" minimum block letter labeling.
14. All securing screws shall be captive. All panels shall be sealable.
15. Meter socket clip arrangement, refer to Section 9 - Self-Contained Meter Sockets.

<p>Electric Service Specifications</p>  <p>PROPRIETARY MATERIAL</p>	<p>METERING & SES SWITCHBOARD, SELF-CONTAINED W/ FACTORY-INSTALLED TEST BLOCK BYPASS COMMERCIAL/RESIDENTIAL, 200 A MAX.</p>	<p>ISSUE DATE: 09/18/90</p>
	<p>9-6-1</p>	<p>REV. DATE: 10/17/12</p> <p>APPROVAL: W. Laramie</p> <p>8509E70.DGN</p>

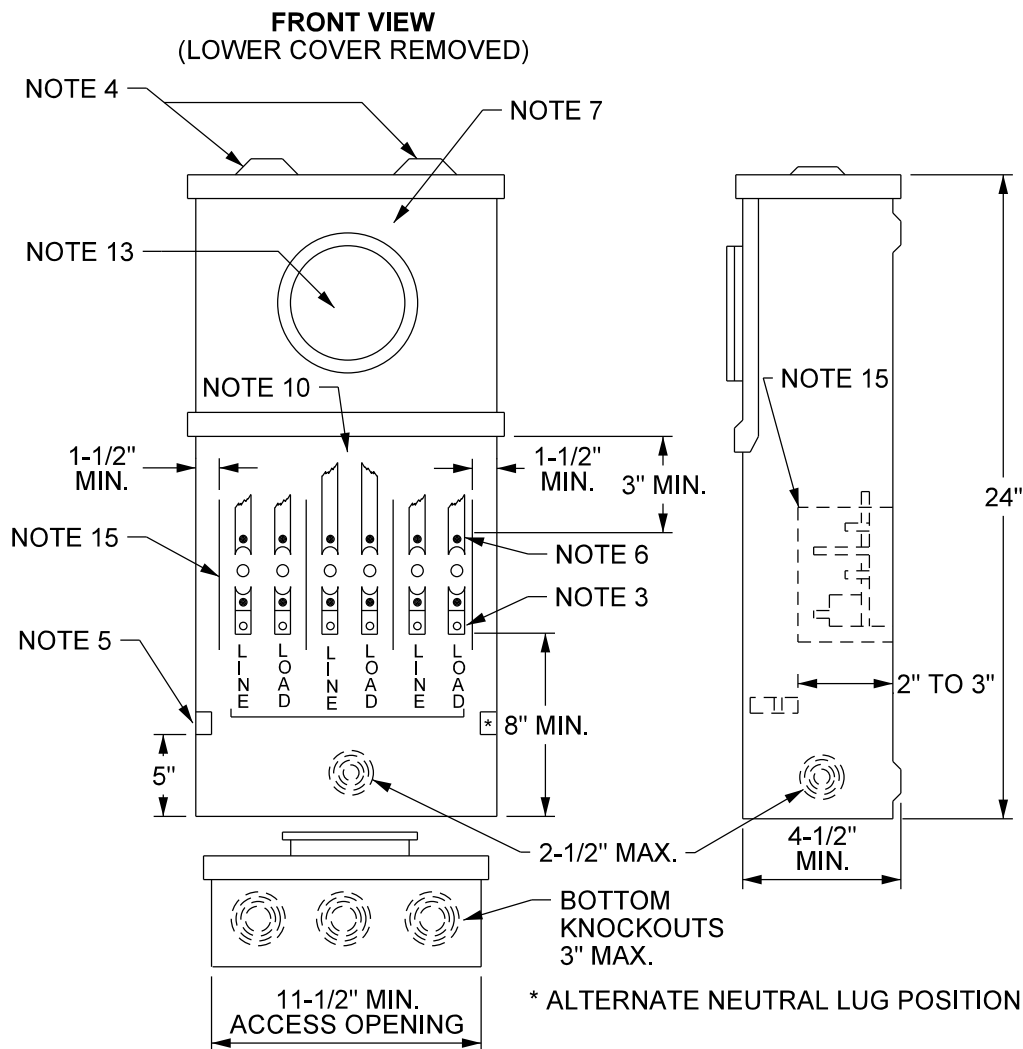

* ALTERNATE NEUTRAL LUG POSITION

NOTES: (Reference EUSERC Drawing 304)

1. This type of device shall be used for separately metered installations, refer to Section 9 - Self-Contained Meter Sockets.
2. This device may be used as a combination terminating pull and meter socket box for underground service when approved by SRP.
3. Aluminum-bodied terminals for #6 through 1/0 wire.
4. Hubs capped off if used for underground feed.
5. Insulated bondable vertical lay-in, double neutral lug with 1/0 wire capacity, mounted on either sidewall.
6. Upper test connector studs.
7. All panels shall be independently removable. Upper cover shall be non-removable when meter is in place. Provide a sealing ring with meter panel. Rigidly mount meter socket on a support and attach to the meter panel. Test block bypass compartment cover panel shall be sealable and permanently labeled: "DO NOT BREAK SEALS. NO FUSES INSIDE."
8. For 3Ø, 4-wire, connect 7th jaw to body of neutral lug with No.12 copper wire, white in color.
9. For 3Ø, 4-wire, delta, identify right-hand test block bypass (2 poles) as power leg. Identification color: blue with orange tracer.
10. For 1Ø, 3-wire, omit center test block bypass.
11. For 1Ø, 3-wire, 120/208 volts, omit center test block bypass and connect 5th jaw to body of neutral lug with No. 12 copper wire, white in color.
12. Permanent labels on inside back of enclosure in 3/4" (minimum) high block letters.
13. Meter socket arrangement refer to Section 9 - Meter Sockets.
14. Riser to enter bottom of box on the side OPPOSITE the nipple leading to the main disconnect.
15. Insulated barriers between phase terminatlns and safety socket sidewalls.

<p>Electric Service Specifications</p>  <p>PROPRIETARY MATERIAL</p>	REV: Title block page references aligned; standardized term "Test Block Bypass"	
	<p>METERING & SES SELF-CONTAINED W/ FACTORY-INSTALLED TEST BLOCK BYPASS COMMERCIAL/RESIDENTIAL 100 A MAX.</p>	<p>ISSUE DATE: 09/19/90 REV. DATE: 07/22/25 APPROVAL: J. Robbins</p>
	9-7-1	8509E71.DGN

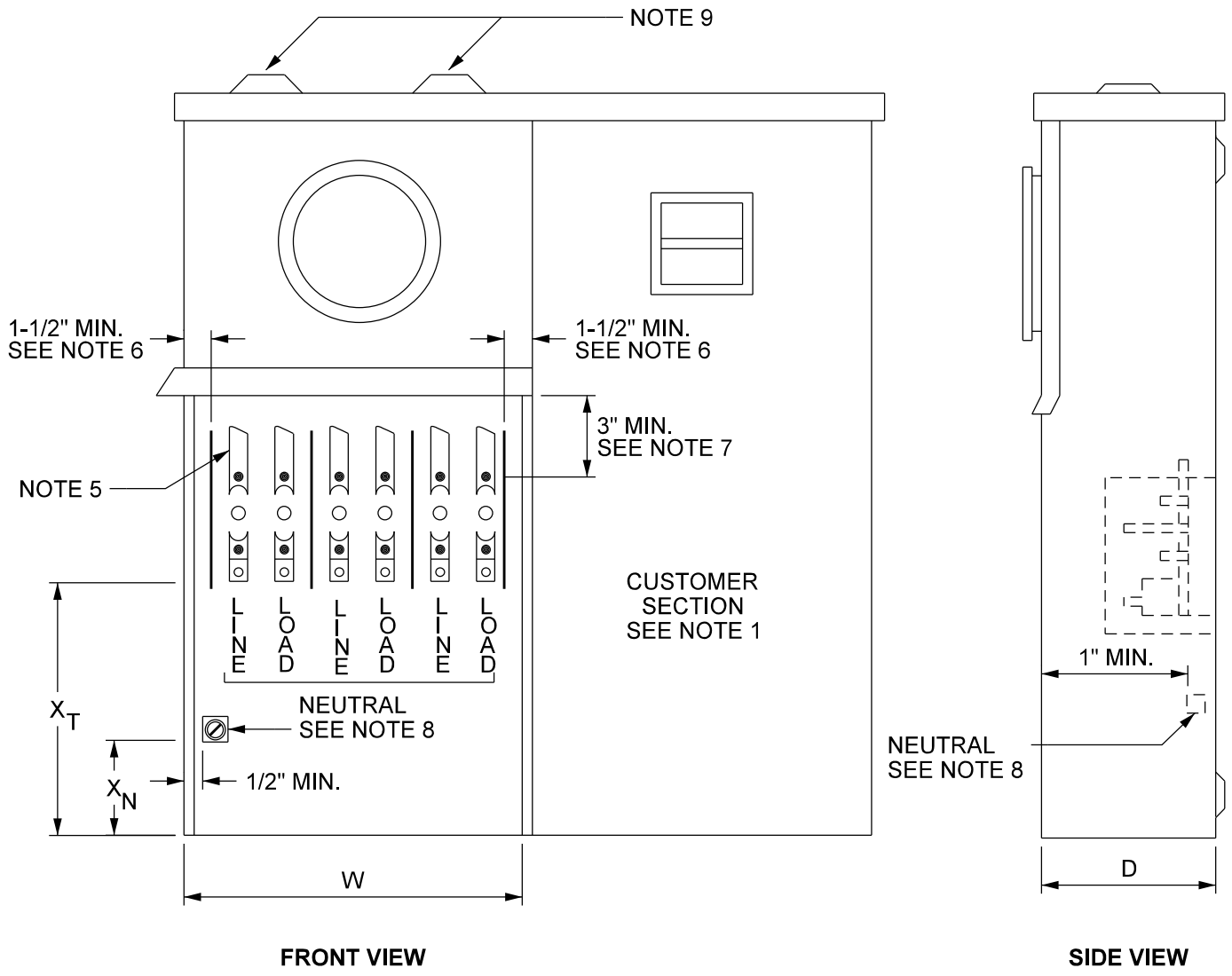



TABLE - MINIMUM DIMENSIONS

PANEL TYPE	PANEL RATING *	D	W SEE NOTE 4	X _T	X _N
STANDARD	100 A	4-1/2"	11-1/2"	8"	5"
HEAVY-DUTY	200 A	6"	13-1/2"	11"	8"

* CONTINUOUS-DUTY

REFERENCE EUSERC DRAWING 305A.

<p>Electric Service Specifications</p>  <p>PROPRIETARY MATERIAL</p>	REV: Updated title block		
	<p>METERING & SES SELF-CONTAINED W/ FACTORY-INSTALLED TEST BLOCK BYPASS & SERVICE DISCONNECT COMMERCIAL/RESIDENTIAL 200 A MAX.</p>		<p>ISSUE DATE: 07/13/07</p> <p>REV. DATE: 07/22/25</p> <p>APPROVAL: J. Robbins</p>
	9-8-1		8509E270.DGN

NOTES

1. The panel shown is typical with the Customer's distribution section located to the side of the metering compartment. The distribution section may also be located below the test-bypass compartment (overhead supply only) or above the meter panel.
2. Meter socket shall be mounted on a rigid support and attached to the meter socket panel.
3. All panels shall be removable without disturbing adjacent panels.
4. Minimum test compartment access opening dimension.
5. Test-bypass blocks with rigid insulating barriers shall be furnished installed and bussed or wired to the meter socket by the manufacturer as follows:
 - A. **For 1Ø, 3-wire:** Provide two test block bypasses mounted in the outer positions and a 4-jaw socket. **120/240V:** Provide two test block bypasses mounted in the outer positions and a 5-jaw socket. Connect fifth jaw of the meter socket to the neutral lug with a white No. 12 AWG (min.) copper wire.
 - B. **3Ø, 3-wire:** Provide three test block bypasses and a 5-jaw meter socket. Connect the line and load poles together at the top of the center position test-bypass block with a bus section, and connect the bus to the fifth jaw of the meter socket with a No.12 AWG (minimum) copper wire. Do not use the color white, gray, green or orange to identify the wire.
 - C. **3Ø, 4-wire:** Provide three test block bypasses and a 7-jaw meter socket. Connect the seventh jaw of the meter socket to the neutral lug with a white No.12 AWG (minimum) copper wire. **120/240V, 4-wire delta:** The right hand test-bypass block shall be the power leg (measures 208 volts-to-ground) and be identified as blue with an orange tracer.
 - D. Test block bypass connection sequence shall be LINE-LOAD from left to right and shall be clearly identified in 3/4" minimum block letters.
 - E. Cable terminals shall be aluminum-bodied mechanical lugs with a range on No. 6 AWG through 1/0 AWG for the 100 ampere test-bypass block and 1/0 AWG through 250 KCMIL for the 200 ampere test-bypass block.
6. 1-1/2" min. dimension measured from compartment side to the test-bypass block rigid insulating barrier.
7. 3" min. dimension measured from the upper test connector stud (stud A) to the socket meter cover.
8. The neutral terminal may be provided as follows:
 - A. A single mechanical lug or lay-in lug, located on either side or side wall. The lug shall be mounted on a neutral bus bar extending into, and terminating in, the Customer section.
 - B. Two mechanical lugs or lay-in lugs, located on either side or side wall. The neutral conductor provided from one of the lugs to the neutral bus in the Customer section may be factory or field installed.
 - C. Overhead supply only - a single insulated, bondable, vertical, lay-in lug located on either side or side wall with the neutral conductor installed unbroken through the lug and terminating on the neutral bus in the Customer section.
9. Knockouts for the service supply conduit may be cut in the locations shown at the top of the panel.

	REV: Updated title block & standardized term "Test Block Bypass"	
	METERING & SES SELF-CONTAINED W/ FACTORY-INSTALLED TEST BLOCK BYPASS & SERVICE DISCONNECT COMMERCIAL/RESIDENTIAL 200 A MAX.	ISSUE DATE: 07/13/07 REV. DATE: 07/22/25 APPROVAL: J. Robbins
	9-8-2	ESS9-8-2.doc

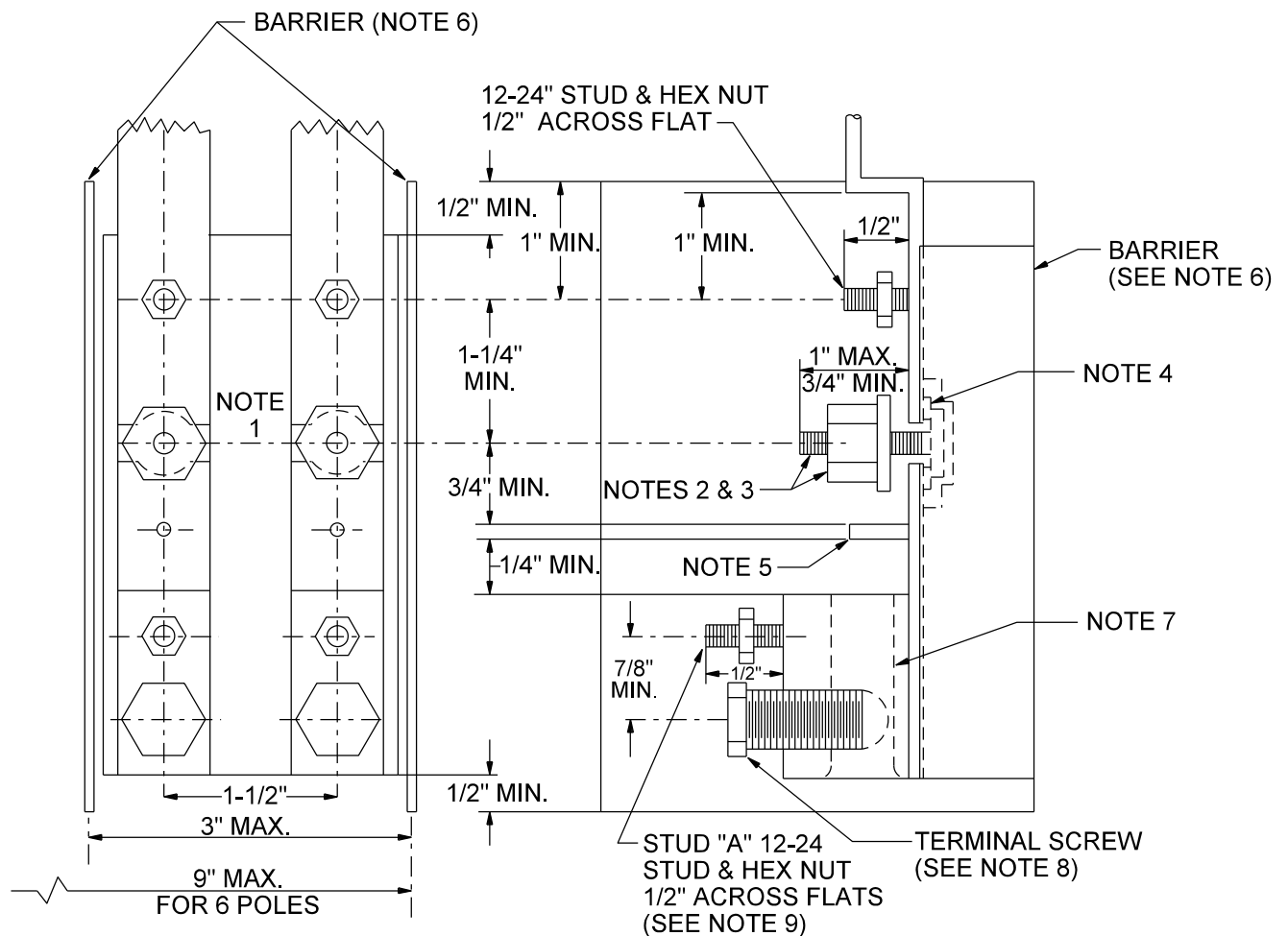

NOTES (Reference EUSERC Drawing 311)

1. Strike distance between upper and lower bus sections shall not be less than 1/4" when shorting nut is backed off.
2. Circuit-closing nut shall be a hex nut 5/8" across flats with plated copper washer attached and have threads counter-bored at bottom to facilitate re-installation. Bolt head shall be secured in place to prevent turning and back out.
3. The circuit-closing nut and bolt assembly shall maintain the applied contact pressure between the plated copper washer and the bus members of the test-bypass block.
4. Insulating washer shall be made from dimensionally stable, non-tracking material and shall provide a minimum of 1/8" creep distance between the bolt and the bus sections. Bus sections shall be plated.
5. Wire stops shall extend to center of terminal opening or beyond.
6. Rigid insulating barriers shall project at least 1/4" beyond any energized parts when the maximum wire size is installed.
7. Terminals shall be aluminum bodied. For required conductor range, see EUSERC Drawings 304 and 305. The opening shall extend through the terminal body and, if wire hole is round, shall be chamfered as necessary to facilitate installation of the largest wire size.
8. The terminal screw may be of the allen type (3/16" across flats for 100 amps, 5/16" across flats for 200 amps). If stud "A" is a part of the terminal screw, the terminal screw shall be 5/8" hex across flats.
9. Place stud "A" in any of the following locations: the clear area between the terminating lug and the circuit-closing nut, or on the terminal body, terminal screw, bus member or incorporated as part of the wire stop.
10. All designs must receive approval of the EUSERC material standards committee prior to production.

<p>Electric Service Specifications</p>  <p>PROPRIETARY MATERIAL</p>	REV: Updated title block	ISSUE DATE: 01/30/25
	<p>METERING & SES TEST BLOCK BYPASS, FACTORY-INSTALLED COMMERCIAL/RESIDENTIAL 200 A MAX.</p>	REV. DATE: 07/22/25
	9-9-1	APPROVAL: J. Robbins
		8509E110.DGN

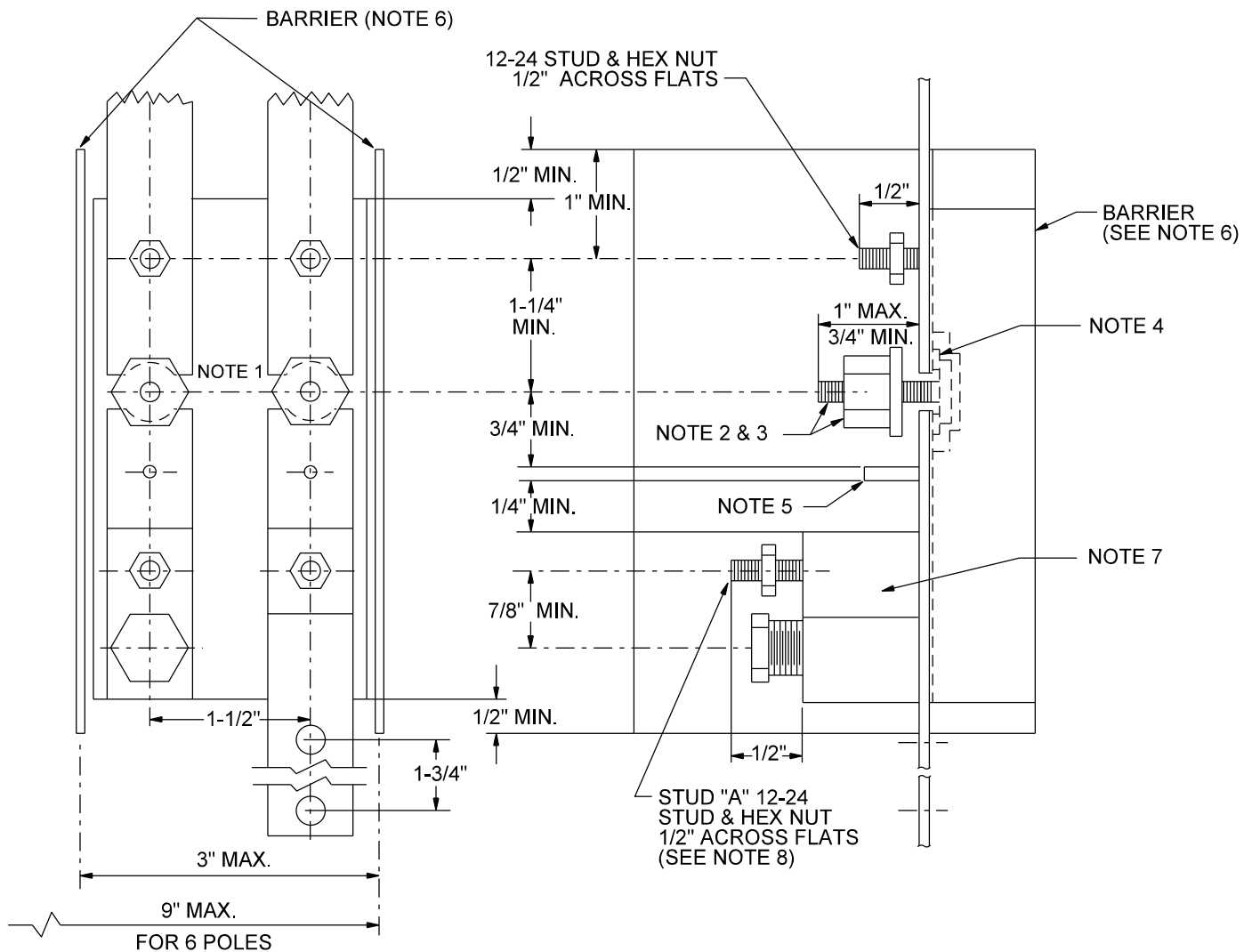

NOTES (Reference EUSERC Drawing 312)

1. Strike distance between upper and lower bus sections shall not be less than 1/4" when shorting nut is backed off.
2. Circuit-closing nut shall be a hex nut 5/8" across flats with plated copper washer attached and have threads counter-bored bottom to facilitate re-installation. Bolt head shall be secured in place to prevent turning and back out.
3. The circuit-closing nut and bolt assembly shall maintain the applied contact pressure between the plated copper washer and the bus members of the test-bypass block.
4. Insulating washer shall be made from dimensionally stable, non-tracking material and shall provide a minimum of 1/8" creep distance between the bolt and the bus sections. Bus sections shall be plated.
5. Wire stops are not required if line and/or load is connected with bus bar. If cable terminals are used, construction requirements shall apply in Section 9 - Switchboard, Self-Contained w/ Factory-Installed Test Block Bypass Commercial/Residential, 200 A Max.
6. Rigid insulating barriers shall project at least 1/4" beyond any energized parts when the maximum wire size is installed.
7. Termination of bus bar and cable line or load conductors may be cable as per EUSERC drawing 311 or bus as per this drawing. If bus and cable terminations are used together, proper locations and alignment of stud "A" must be maintained to facilitate installation of bypass jumper.
8. Stud "A" shall be located in the clear area between the terminating lug and the circuit-closing nut, and may be positioned on: terminal body, terminal screw, bus member, or incorporated as part of the wire stop.
9. Serviceability - The line and/or load bus is to be connected to the bus block member in a manner which will allow ready replacement of the test-bypass block assembly.
10. All designs must receive approval of the EUSERC Material Standards Committee prior to production.

<p>Electric Service Specifications</p>  <p>PROPRIETARY MATERIAL</p>	REV: Updated title block		
	<p>METERING & SES TEST BLOCK BYPASS, FACTORY-INSTALLED COMMERCIAL/RESIDENTIAL 200 A MAX. BUSSED/CABLE TERMINATIONS</p>		<p>ISSUE DATE: 01/30/94 REV. DATE: 07/22/25 APPROVAL: J. Robbins</p>
	9-10-1		8509E116.DGN

Concrete Pad Notes:

1. All free standing SESs shall be placed on a concrete pad extending a minimum 3' in front of SES with drainage away from the cabinet. For additional requirements refer to Section 5 - Clearances, SES Location, Height & Work Space Clearances.

EXCEPTION:

- a. Pedestals rated 200 A and less do not require a concrete pad extension
 - b. 5' drivable path, (except for drainage slope).
2. Parking not allowed within 5' of SES.
 3. Pad (work space) shall be at the same elevation as SES. SES installed on an elevated (house keeping) pad above the workspace is not permitted.

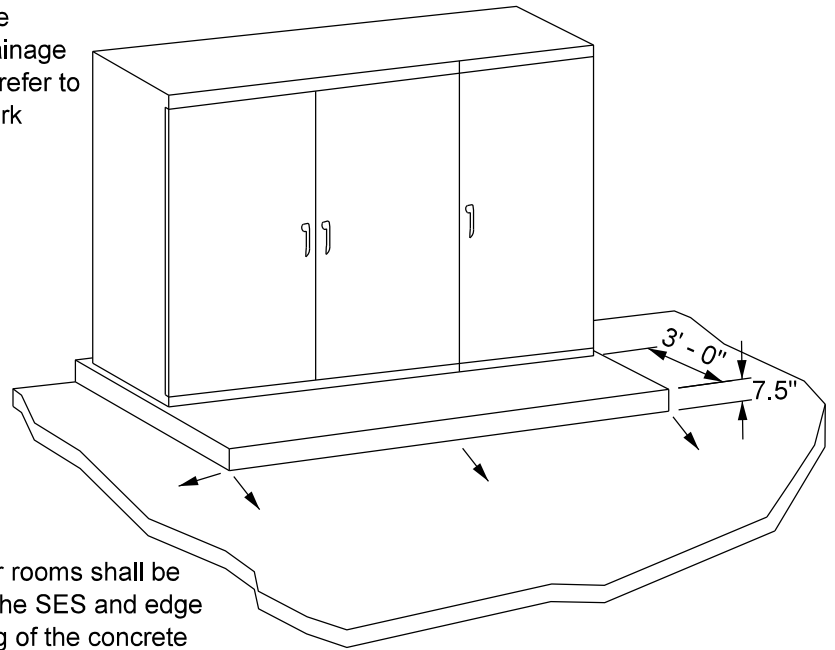

EXCEPTION: NEMA 1 enclosures installed in meter rooms shall be positioned to have maximum of 4" from the face of the SES and edge of the concrete pad to minimize cracking or breaking of the concrete pad when anchoring bolts near the pad's edge.

Switchboard Service Section Defined

1. A standard switchboard service section is a free-standing unit of switchgear that contains bussing for the termination of service entrance conductors, bussing for the connection and mounting of current transformers, panel for the installation of the test switch and meter socket, a service main disconnect switch or breaker, and in many cases, distribution feeder breakers or switches.
2. Switchboard service sections approved for use in the area served by SRP, shall be built to the standards developed by the EUSERC. These are available to customers and contractors through electric wholesale distributors or by purchasing a EUSERC manual from EUSERCUS.com.
3. If service riser conductors are to be paralleled, they shall be paralleled in separate conduits. The only acceptable method is to install one of each phase conductor and neutral in each conduit (i.e., ABC of a 3-wire service or ABCN of a 4-wire service). If overhead service risers are to be paralleled, there shall be a maximum of two conductors per phase.
4. Overhead service entrance conductor requirements exceeding 800 amps or exceeding two 750 MCM conductors per phase shall be bus bar construction.
5. Submit electronic copies of the plans (PDF format) for all proposed SES, 400 amps or larger, to shopdraw@srpnet.com for approval prior to construction of the service section. Drawings must be labeled with the Customer's name, job address, SRP job number or account number, and contractor's name and contact phone number.
6. All SES shall be braced for the total available fault current.
7. The above requirements apply to both overhead and underground SES.
8. Barriers shall be constructed from 16 gauge (min.) steel and secured so as not to be removable from either the Customer's section or exterior.
9. Door locking requirements, refer to Section 9 - Switchboards, Current Transformer Meter Panel Clearance Outdoor.

Switchboard Service Section Defined

1. Within Section 9 are EUSERC drawings illustrating the metering and pull section requirements.

	REV: Add section title for notes on concrete pad; update illustration and notes	ISSUE DATE: 04/15/88
	<p style="text-align: center;">METERING & SES SWITCHBOARDS GENERAL INFORMATION</p> <p style="text-align: center;">9-11-1</p>	REV. DATE: 07/08/25 APPROVAL: J. Robbins
		8509E100.DGN

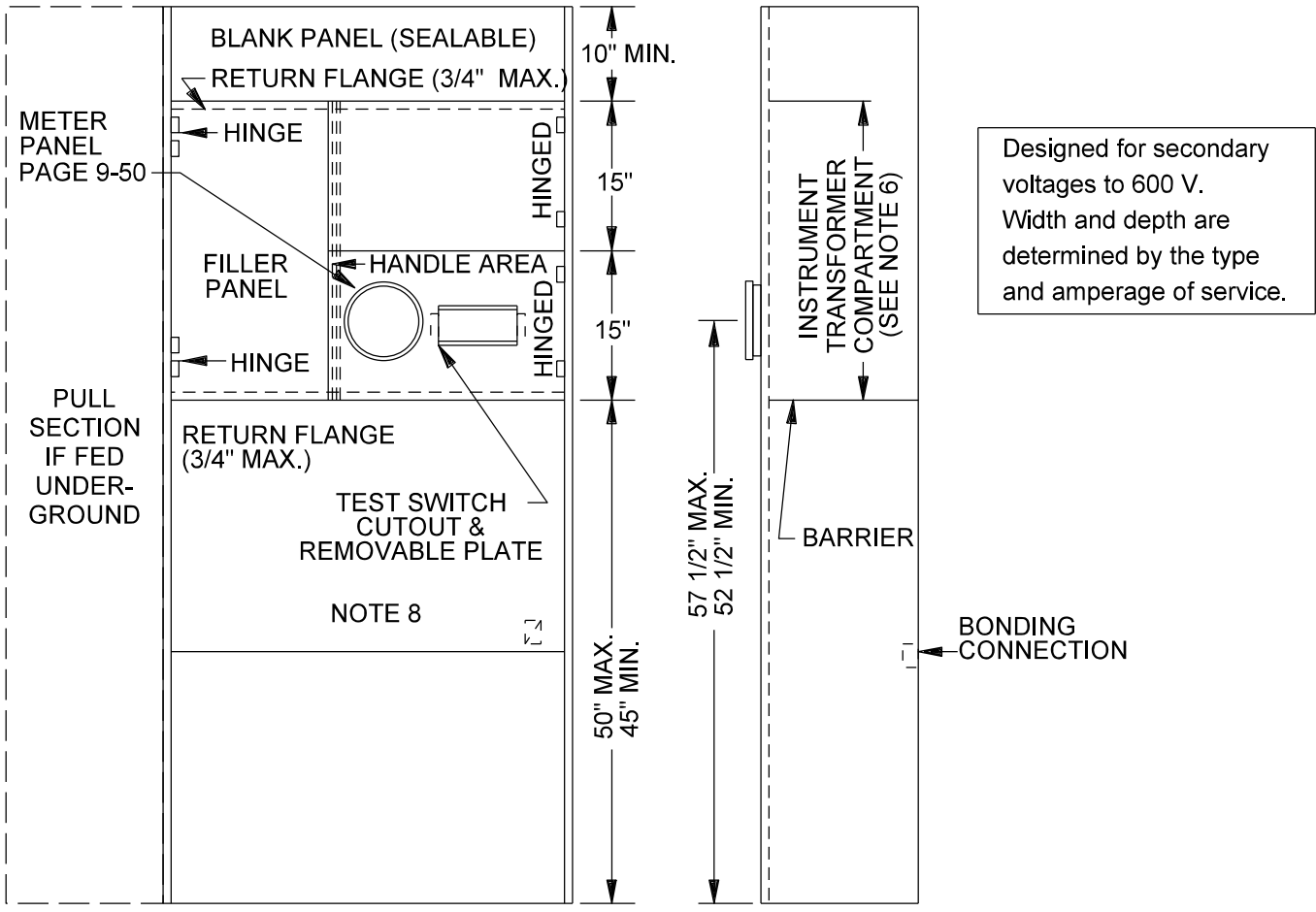

NOTES (Reference EUSERC Drawing 326)

1. Instrument transformer compartments shall be bussed with rectangular bus bar.
2. The ground connection shall be made in the main switch or breaker compartment.
3. Meter and blank panels shall be constructed of 12-gauge steel (minimum) and shall be reversible, sealable, hinged and interchangeable.
4. Filler panels shall be used where the service section exceeds the meter panel width. Meter panels, either socket or blank, shall not be hinged to hinged filler panels. Non-hinged filler panels shall not extend into the required current transformer compartment access opening.
5. All panels shall be equipped with stops to prevent inward swinging beyond the front surface of the service section. Hinges shall be readily interchangeable, right or left, on the job site.
6. In some cases, the width of meter panels may require the service section to be wider than the minimum allowable width of the transformer compartment. For minimum dimensions of instrument transformer compartments refer to the following pages:
 - 400 to 1000 Amps.....Refer to Switchboards, 0-600 Volts Instrument Transformer Compartment 1 Ø 3-Wire 400-1,000 Amps
 - 1,001 to 3000 Amps.....Refer to Switchboards, 0-600 Volts Instrument Transformer Compartment 3 Ø 4-Wire 1,001-3000 Amps
 - 3,001 Amps and above (Reference only).....Refer to Switchboards, 0-600 Volts Instrument Transformer Compartment 3 Ø 4-Wire 3,001 Amps & Larger
7. All securing screws shall be captive. All panels and covers shall be sealable.
8. When used as a bottom fed service-terminating section, see EUSERC Drawing no. 327.
9. Submit electronic copies of the plans (PDF format preferred) for all proposed SES, 400 amps or larger, to shopdraw@srpnet.com for approval prior to construction of the service section. Drawings must be labeled with the Customer's name, job address, SRP job number or account number, and contractor's name and contact phone number.
10. Outdoor applications, refer to Section 9 - Switchboards, Current Transformer Meter Panel Clearance Outdoor.

 Electric Service Specifications PROPRIETARY MATERIAL	REV: Add Reference Only for existing services above 3,000 A	
	METERING & SES SWITCHBOARDS CURRENT TRANSFORMER COMPARTMENT WITH FILLER PANEL	ISSUE DATE: 09/18/12 REV. DATE: 07/19/24 APPROVAL: J. Robbins
	9-12-1	8509E74.DGN

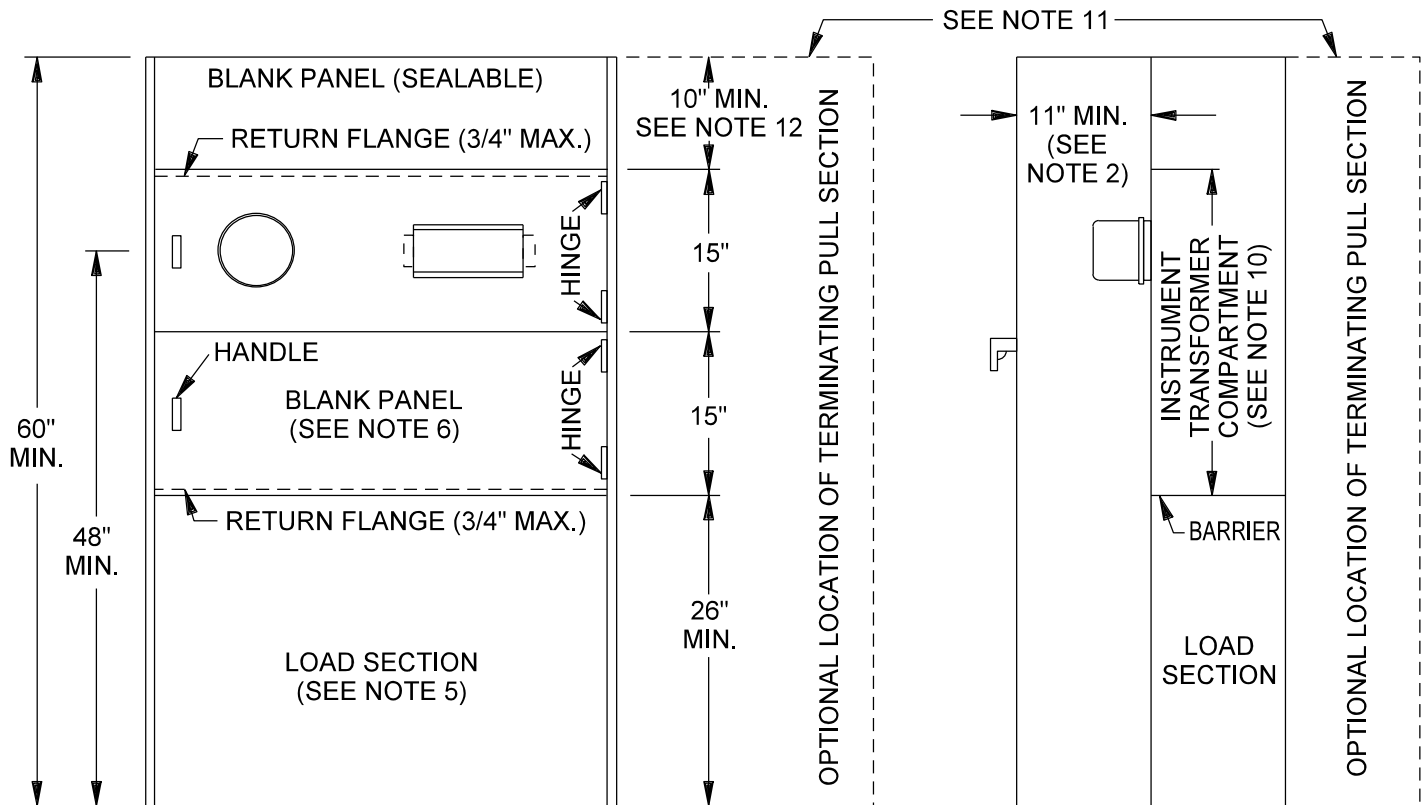

FRONT VIEW

SIDE VIEW

NOTES

1. Terminating pull section shall be located beside or behind the instrument transformer compartment.
2. For outdoor applications only. See EUSERC Drawing 354 for weatherproof enclosure requirements.
3. Instrument transformer compartments shall be bussed with rectangular bus.
4. Filler panels shall be used where the service section exceeds the meter panel width. Meter panels, either socket or blank, shall not be hinged to hinged filler panels. Non-hinged filler panels shall not extend into the required instrument transformer compartment access opening.
5. The grounding connection shall be made in the main switch or breaker compartment.
6. Meter panels shall be constructed of 12-gauge (min.) steel and shall be reversible, sealable, hinged and interchangeable. See EUSERC Drawing 332 for socket meter panel details.
7. Hinges shall be readily interchangeable, left or right, on the job site.
8. Width of meter panels may in some cases require the service section to be wider than the minimum allowable width of the instrument transformer compartment.
9. Meter panels shall be equipped with stops to prevent inward swinging beyond the front surface of the service section.
10. For requirements regarding instrument transformer compartments, see 0 to 1000 amperes, see EUSERC Drawings 319 and 320.
11. Switchboards 400 amps and above shall be provided with landing lugs in the cable pull section.
12. Dimension may be reduced if the service section is supplied from horizontal cross-bussing.

<p>Electric Service Specifications</p>  <p>PROPRIETARY MATERIAL</p>	<p>METERING & SES SWITCHBOARD LOW-PROFILE, 1000 A MAX</p>	<p>ISSUE DATE: 03/13/08</p>
	<p>9-13-1</p>	<p>REV. DATE: 10/17/12</p> <p>APPROVAL: W. Laramie</p> <p>8509E278.DGN</p>

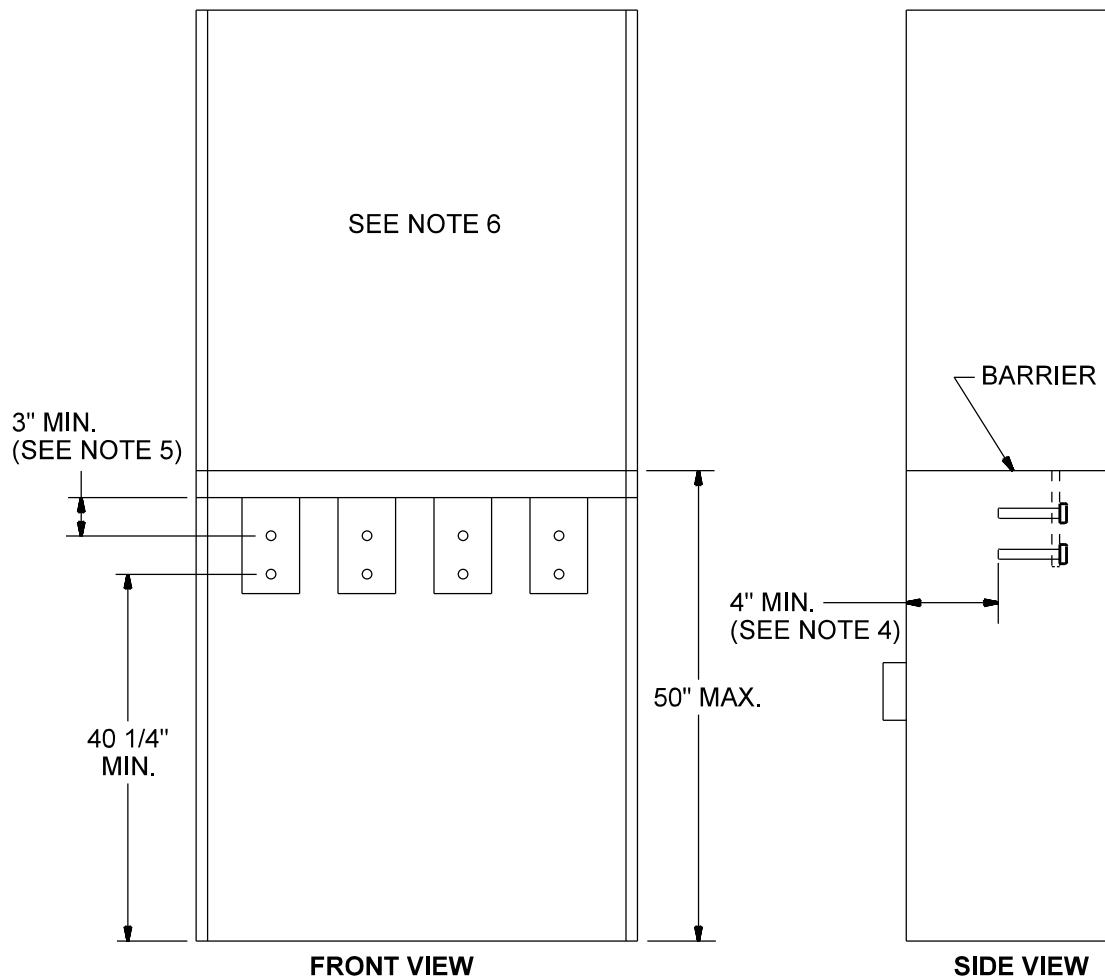

NOTES (Reference EUSERC Drawing 327)

1. The pull section may supply either a current transformer compartment or a main service disconnect device.
2. Pull section covers shall be:
 - A. Independent of other equipment and removable without disturbing adjacent panels.
 - B. Sealable, provided with two lifting handles and limited to a maximum of 9 square feet in area.
3. The pull section shall be equipped with terminating facilities, refer to Section 9 - Terminating Facilities Underground Pull Boxes or Pull Sections. Terminating facilities shall be secured to prevent misalignment and shall be rigid without the installation of current transformers.
4. The clearance from the energized bus to the pull section removable access covers may be reduced if the manufacturer provides a safety barrier. For additional clearance and barrier requirements, see EUSERC Drawing 347, Note 13.
5. A vertical clearance of 3" minimum shall be maintained between the centerline of the top bolts of the terminating facilities to any obstruction.
6. When the upper section is:
 - A. An Instrument transformer compartment; for additional service section requirements refer to Section 9 - Test Block Bypass, Factory-Installed Commercial/Residential 200 A Max. Bussed/Cable Terminations and Section 9 - Switchboards - General Information Barrier Illustration.
 - B. A main service disconnect device:
 - 1) A full width and depth, insulated, rigid barrier shall be provided to separate the pull section and main service disconnect compartment.
 - 2) The main service disconnect cover shall be sealable.
7. Sealing provisions for removable covers shall consist of two drilled stud and wingnut assemblies located on opposite sides of the cover. Hinged covers shall be sealed on the unsupported side (refer to Section 9 - Service Entrance Section Lock Box & Seals).

<p>Electric Service Specifications</p>  <p>PROPRIETARY MATERIAL</p>	<p>METERING & SES SWITCHBOARDS COMBINATION PULL SECTION 1,000 A MAX</p>		<p>ISSUE DATE: 02/14/01</p>
	<p>9-14-1</p>		<p>REV. DATE: 10/19/12</p> <p>APPROVAL: W. Laramie</p> <p>8509E407.DGN</p>

DESIGNED FOR SECONDARY VOLTAGES TO 600 VOLTS. THE WIDTH AND DEPTH ARE DETERMINED BY THE TYPE AND AMPERAGE OF SERVICE.

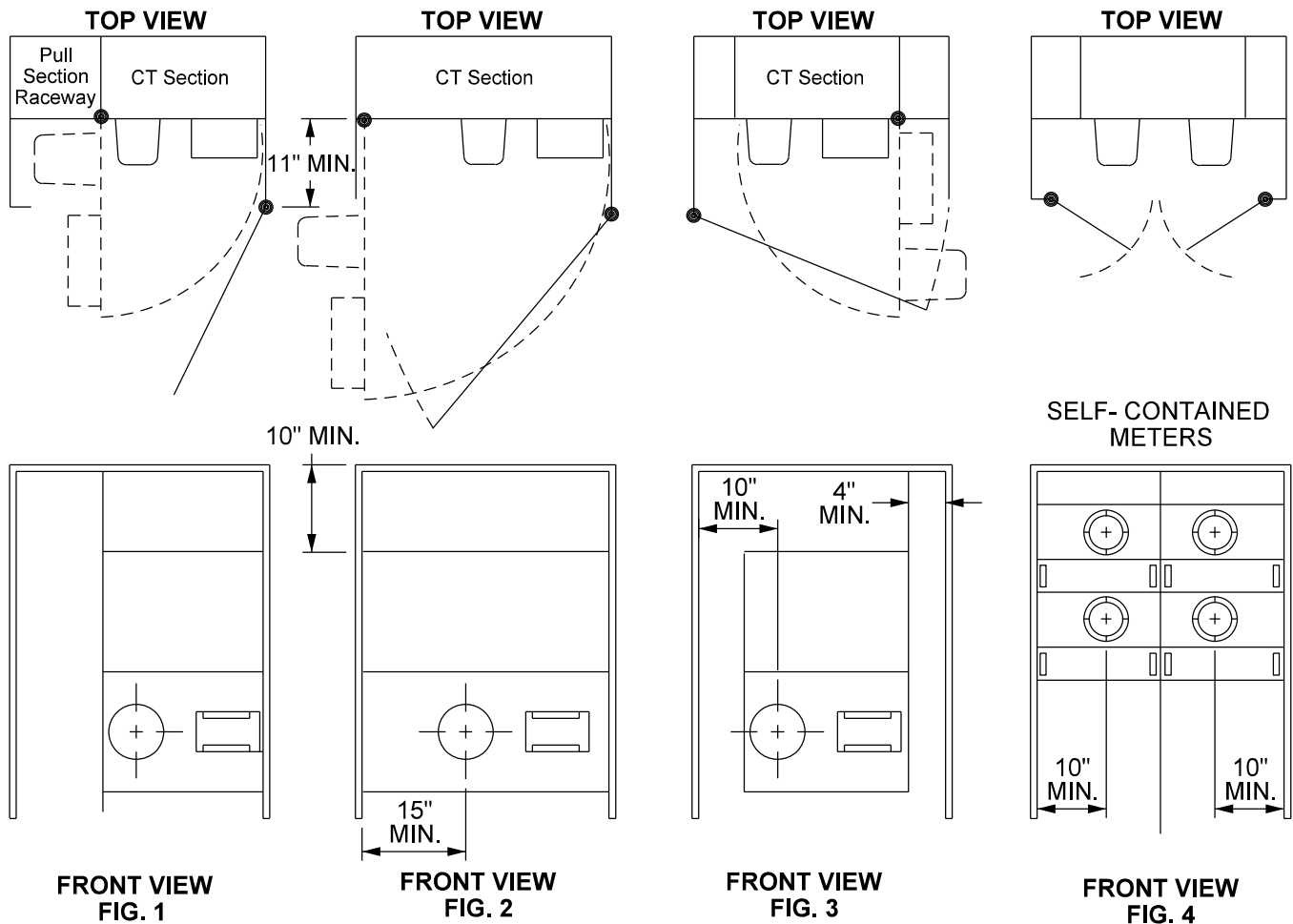

OUTDOOR RAIN TIGHT CONSTRUCTION

NOTES (Reference EUSERC Drawing 354)

1. Hinged meter panels shall be capable of being opened 90° with meter and test facilities in place. The hinges shall be interchangeable, right or left, on the job site.
2. Enclosure doors providing access to utility compartments (i.e., metering sections and pull sections) shall be:
 - A. Equipped with a device to secure the doors in the open position at 90° or more.
 - B. Secured in the closed position with a single, handle-operated latching system. When provided with a locking means, each door or set of doors shall be equipped with an approved double-locking device accepting padlocks with a 5/16" lock shaft, to allow access by both the serving utility and the Customer.
3. Where an adjacent obstruction extends more than 11" perpendicular from the face of the meter panel, a 10" minimum dimension to the meter socket axis is required. For obstructions extending 11" or less from the meter panel, the side clearance shall be a minimum of 6 1/4".
4. All panels and covers shall be sealable.
5. Refer to the following pages for bussed current transformer compartment details and dimensions:
 - 400 to 1,000 Amps.....Refer to Switchboards, 0-600 Volts Instrument Transformer Compartment 1 Ø 3-Wire 400-1,000 Amps
 - 1,001 to 3,000 Amps.....Refer to Switchboards, 0-600 Volts Instrument Transformer Compartment 3 Ø 4-Wire 1,001-3000 Amps
 - 3,001 Amps and above (Reference only).....Refer to Switchboards, 0-600 Volts Instrument Transformer Compartment 3 Ø 4-Wire 3,001 Amps & Larger

	REV: Add Reference Only for existing services above 3,000 A	
	METERING & SES SWITCHBOARDS CURRENT TRANSFORMER METER PANEL CLEARANCE OUTDOOR	ISSUE DATE: 09/20/90 REV. DATE: 07/19/24 APPROVAL: J. Robbins
	9-15-1	8509E75.DGN

DESIGNED FOR SECONDARY VOLTAGES TO 600 VOLTS. THE WIDTH AND DEPTH ARE DETERMINED BY THE TYPE AND AMPERAGE OF SERVICE.

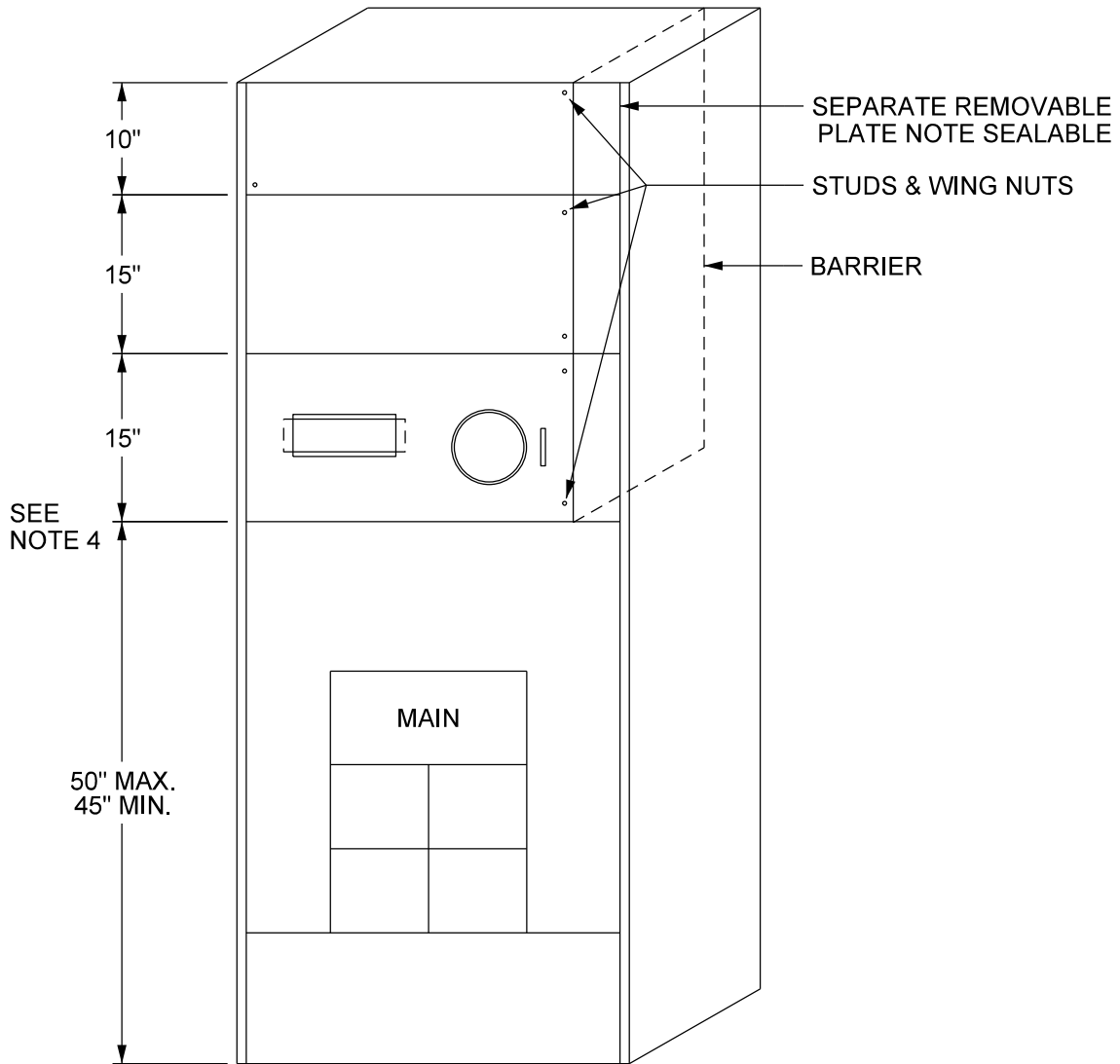

NOTES

1. This drawing shows a separate barriered load wireway at the upper right side of the switchboard in order to route the load conductors out the top. Load conductors may not be routed through the current transformer compartment in order to exit the switchboard.
2. Access to the Customer's distribution wireways shall not require opening or removing sealable panels.
3. All panels and covers shall be sealable.
4. Dimensions may be reduced if the service section is supplied from horizontal cross-bussing or bus duct (See EUSERC Drawing 326).
5. Submit electronic copies of the plans (PDF format preferred) for all proposed SES to shopdraw@srpnet.com for approval prior to construction of the service section. Drawings must be labeled with the Customer's name, job address, SRP job number or account number, and contractor's name and contact phone number.

<p>Electric Service Specifications</p>  <p>PROPRIETARY MATERIAL</p>	<p>METERING & SES SWITCHBOARDS - GENERAL INFORMATION BARRIER ILLUSTRATION</p>		<p>ISSUE DATE: 04/15/86</p>
	<p>9-16-1</p>		<p>REV. DATE: 10/17/12 APPROVAL: W. Laramie</p>

8509E323.DGN

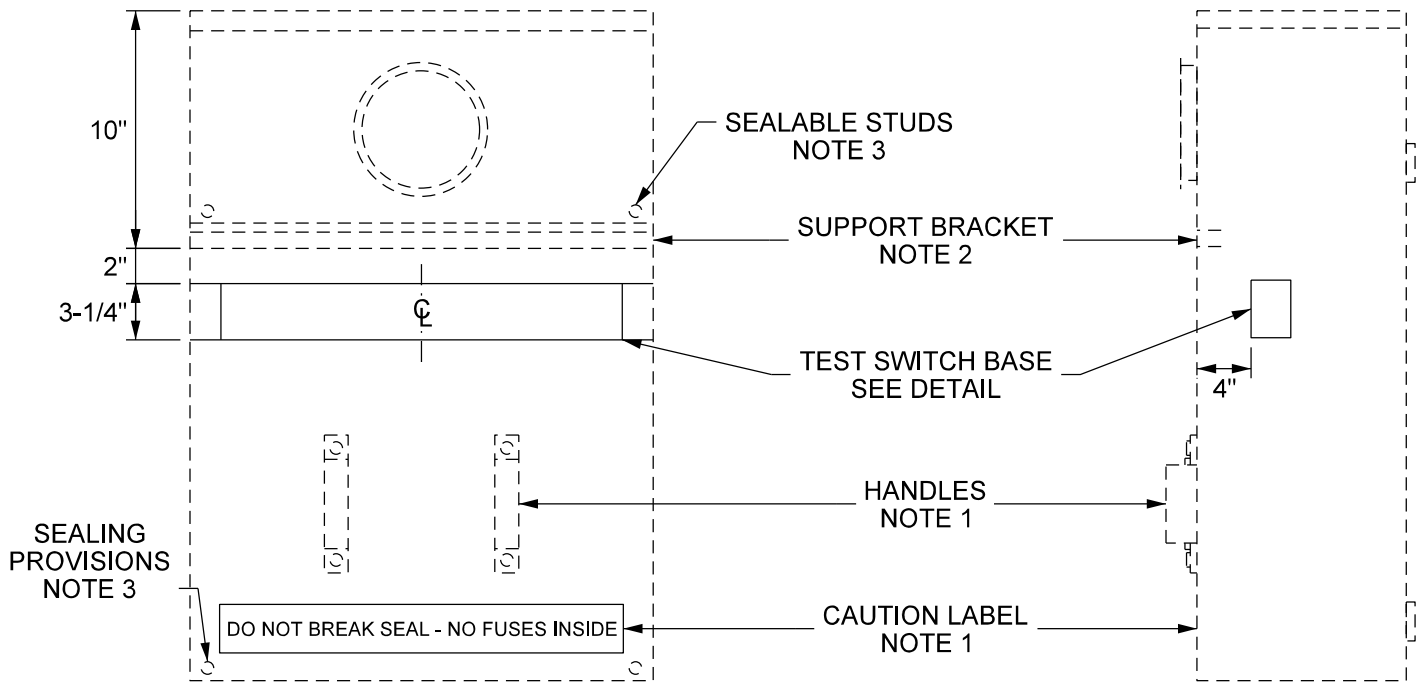

FRONT VIEW

SIDE VIEW

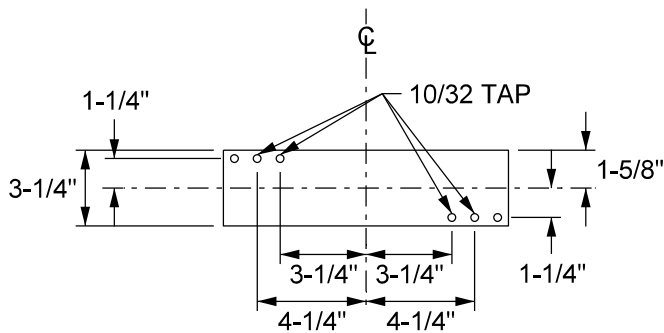

**TEST SWITCH BASE
DETAIL**

NOTES

1. Cover panel shall be provided with two lifting handles and caution sign on the front reading "DO NOT BREAK SEAL - NO FUSES INSIDE".
2. Secure the meter panel to the support bracket to prevent panel from pulling out when meter is removed.
3. Covers shall be sealable.
4. Pull section required for underground applications.

<p>Electric Service Specifications</p>  <p>PROPRIETARY MATERIAL</p>	<p>METERING & SES TEST SWITCH MOUNTING BASE, REMOVABLE WALL-MOUNTED SES</p>	<p>ISSUE DATE: 02/19/25</p>
	<p>9-17-1</p>	<p>REV. DATE:</p> <p>APPROVAL: J. Robbins</p> <p>8509E406.DGN</p>

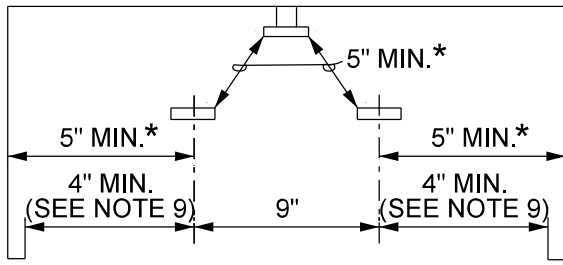

*SEE NOTE 6

TOP VIEW

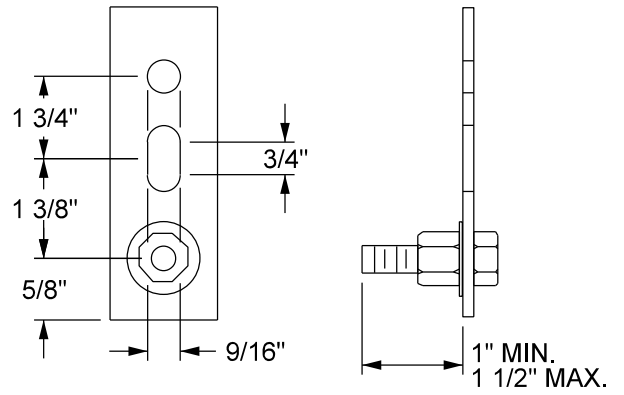

BUS DRILLING DETAIL
TYPICAL 4 LOCATIONS
(SEE NOTE 3)

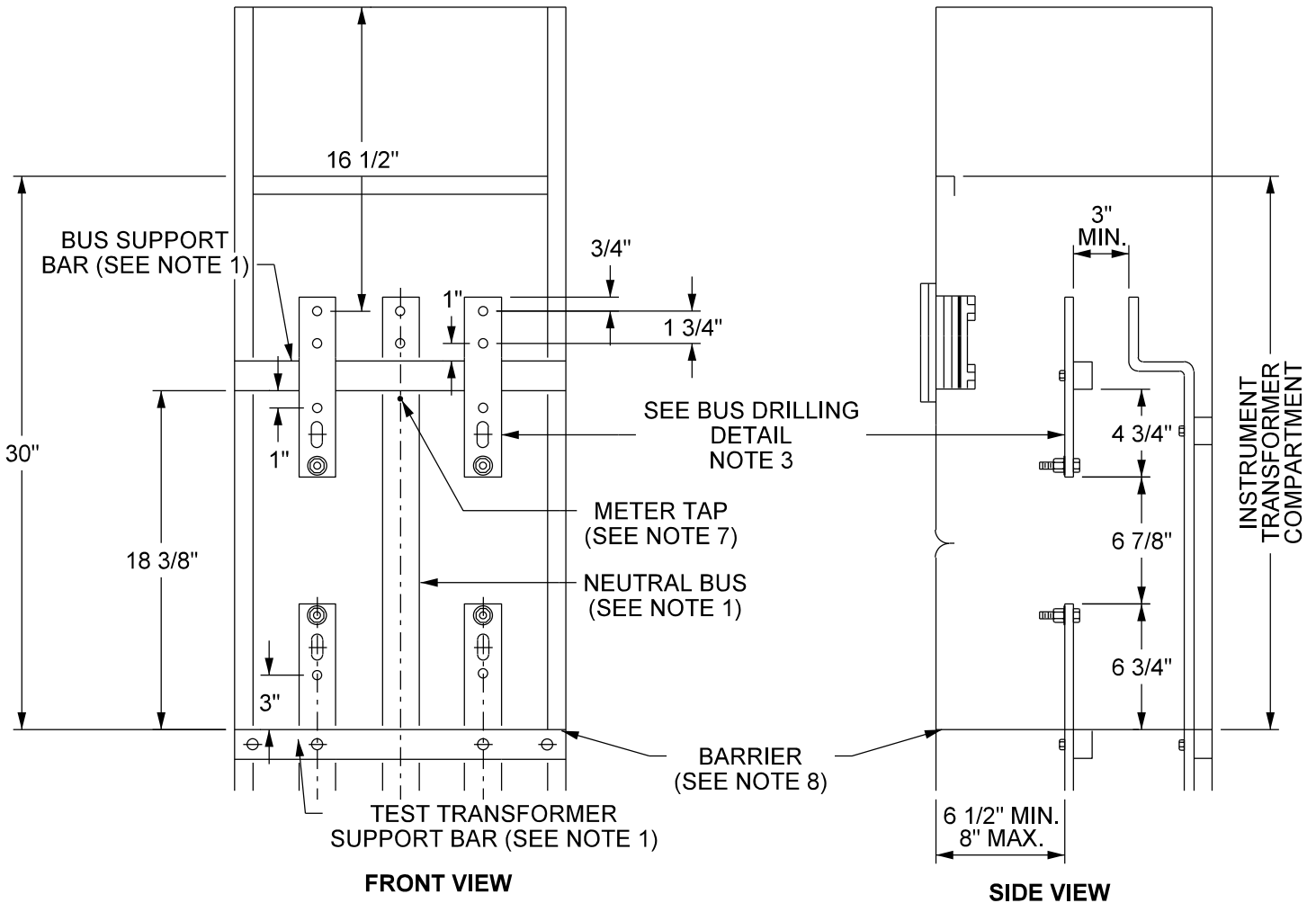

(REFERENCE EUSERC DRAWING 319)

<p>Electric Service Specifications</p>  <p>PROPRIETARY MATERIAL</p>	<p>REV: Add EUSERC reference; update title block remove 3PH 3-WIRE</p>		
	<p>METERING & SES SWITCHBOARDS, 0-600 VOLTS INSTRUMENT TRANSFORMER COMPARTMENT 1Ø 3-WIRE 400-1000 AMPS</p>		<p>ISSUE DATE: 02/20/08</p>
	<p>9-18-1</p>		<p>REV. DATE: 02/19/25</p> <p>APPROVAL: J. Robbins</p>
		<p>8509E284.DGN</p>	

NOTES

1. Bus arrangement and supports shall be provided as shown, except the neutral bus may be located at either side or on either side wall. Bus supports shall be constructed of a continuous bar of insulating material and shall be rigid to prevent misalignment of the bus units with the cables in place.
2. The bus units may be supplied from the top or bottom and shall be anchored to prevent turning. Bus units shall be constructed of rectangular bus, and when laminated shall have no space between laminations. Bus dimensions shall be: A minimum of 1/4 x 2" and a maximum of 3/4 x 2".
3. Bus unit shall be provided with a fixed stud as shown for mounting the current transformers. Each shall:
 - A. Consist of a 1/2" steel bolt and shall be provided with a spring washer and a nut. The spring washer may be either a cone-type (Belleville) washer or a split-ring washer and flat washer. All parts shall be plated to prevent corrosion.
 - B. Be secured in place, meaning that the stud will not turn, back out, or loosen in any manner when tightening or loosening the associated nuts (including cross-threaded situations).
4. When the compartment is supplied from horizontal cross-bussing, the bussing shall pass through the compartment or in the sealed area above the compartment.
5. Except for conductors supplying the instrument transformer compartment and the ground bus, no other conductors or devices shall be installed in or routed through the compartment or the sealed area above the compartment. The ground bus shall not infringe on utility compartment space or reduce any clearances. Customer connections to the ground bus shall not be allowed in the instrument transformer compartment.
6. A clear, unobstructed work space shall be provided around the current transformer bus units from the barrier to the upper support bar.
7. Taps for attachment of meter wiring shall be provided on the neutral bus unit shown, or when the compartment is supplied from cross-bussing, a tap may be provided on the neutral cross-bus, or on a bus bar extension provided from the neutral cross-bus. A 10-32 screw and washer shall be provided for the neutral bus. Tap locations shall be centered between phase bus units, or at either side, and shall be readily accessible under energized conditions and with the current transformers in place.
8. The barrier shall be constructed of a rigid insulating material resistant to ARC tracking and shall be secured in place with a maximum deflection of 1/2" from an applied force of 25 pounds downward. Openings in the barrier (i.e., peripheral gaps around barrier, cutouts around bus bars, and hole diameters provided for ventilation) shall not exceed 3/8". The barrier shall be attached with non-conductive fasteners.
9. Dimension shall be measured to inside edge of the compartment access opening.
10. Torque labels shall be provided in each utility compartment where nut and bolt assemblies using cone-type (Belleville) washers are used for utility terminations, test-bypass block circuit-closing nuts, or for securing current transformers or current transformer bus removable links. Labels shall be readily visible and shall not be installed on any removable or hinged cover panel.
11. Wall-mount General application limited to 600 amps, cover panel shall be provided with two lifting handles and caution sign on the front reading "DO NOT BREAK SEAL - NO FUSES INSIDE".

	REV: Added Note 11; SRP no longer provides 3 phase 3-wire	
	METERING & SES SWITCHBOARDS, 0-600 VOLTS INSTRUMENT TRANSFORMER COMPARTMENT 1 Ø 3-WIRE 400-1,000 AMPS	ISSUE DATE: 02/20/08 REV. DATE: 02/19/25 APPROVAL: J. Robbins
	9-18-2	ESS9-18-2.doc

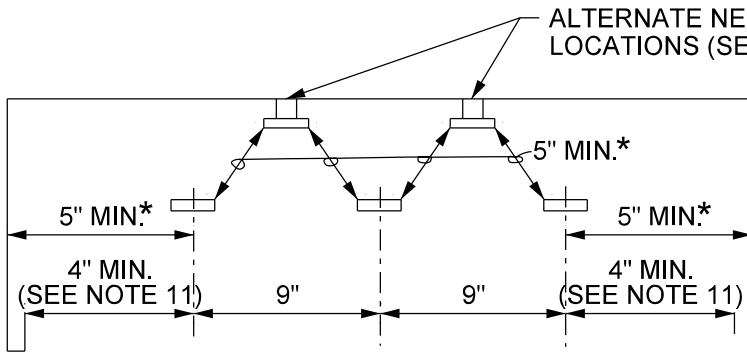

* SEE NOTE 6
TOP VIEW

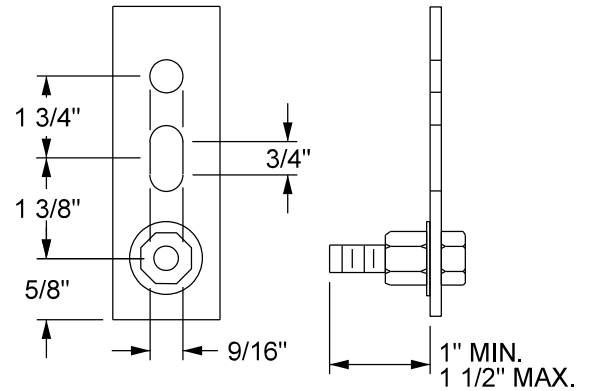

BUS DRILLING DETAIL
TYPICAL 6 LOCATIONS
(SEE NOTE 3)

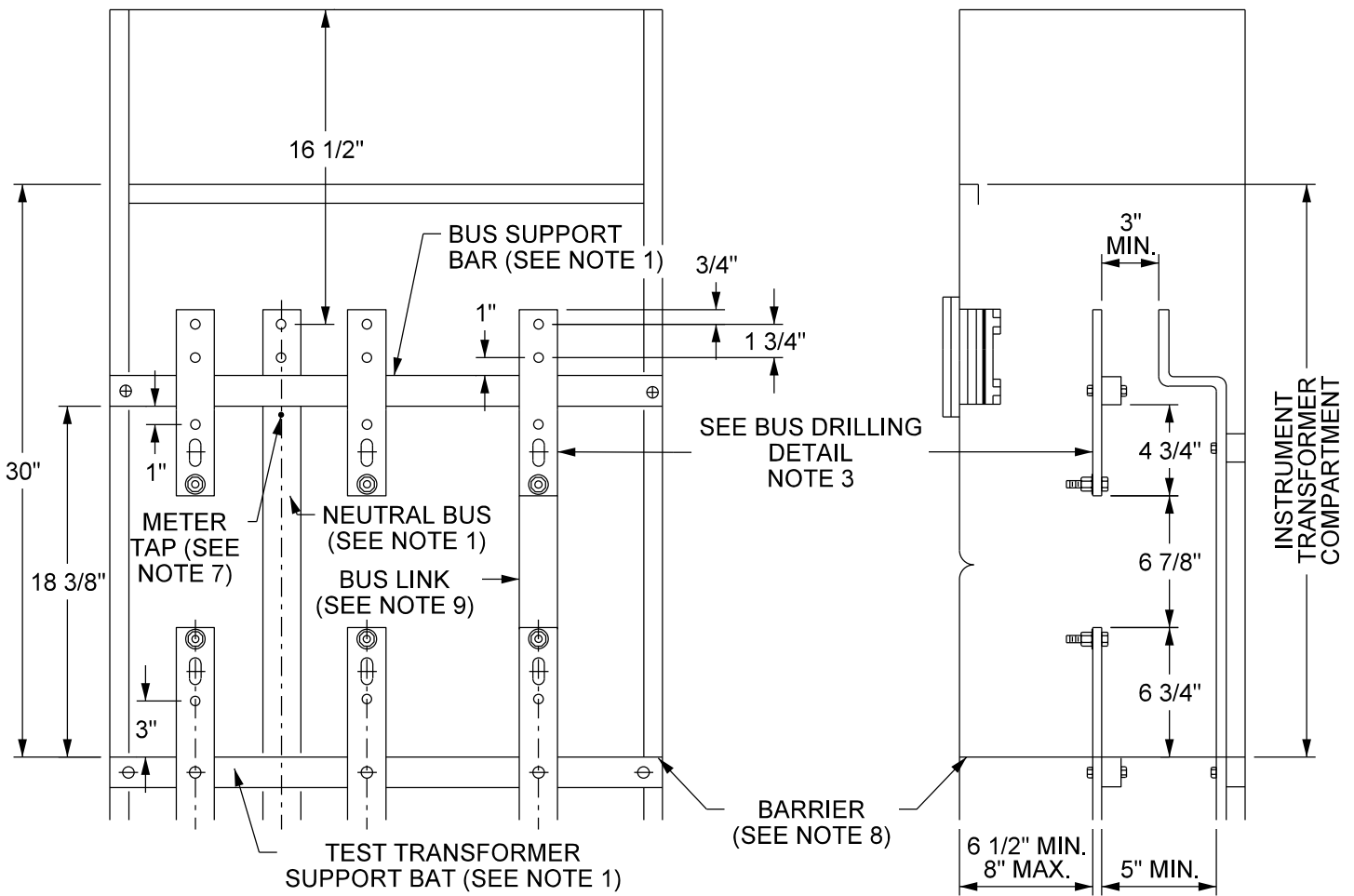

FRONT VIEW

SIDE VIEW

(REFERENCE EUSERC DRAWING 320)

<p>Electric Service Specifications</p>  <p>PROPRIETARY MATERIAL</p>	<p>REV: Add EUSERC reference, SRP no longer provides 3 phase 3-wire</p>	<p>ISSUE DATE: 02/20/08</p>
	<p>METERING & SES SWITCHBOARDS, 0-600 VOLTS INSTRUMENT TRANSFORMER COMPARTMENT 3Ø 4-WIRE 400-1000 AMPS</p>	<p>REV. DATE: 02/19/25</p> <p>APPROVAL: J. Robbins</p>
<p>9-19-1</p>		<p>8509E282.DGN</p>

NOTES

1. Bus arrangement and supports shall be provided as shown, except the neutral bus may be located at either side or on either side wall (neutral bus is not required for 3 Ø, 3-wire service). Bus supports shall be constructed of a continuous bar of insulating material and shall be rigid to prevent misalignment of the bus units with the cables in place.
2. The bus units may be supplied from the top or bottom and shall be anchored to prevent turning. Bus units shall be constructed of rectangular bus, and when laminated, shall have no space between laminations. Bus dimensions shall be provided a minimum of 1/4 x 2" and a maximum of 3/4 x 2".
3. Bus unit shall be provided with a fixed stud as shown for mounting the current transformers. Each shall:
 - A. Consist of a 1/2" steel bolt and shall be provided with a spring washer and a nut. The spring washer may be either a cone-type (Belleville) washer or a split ring washer and flat washer. All parts shall be plated to prevent corrosion.
 - B. Be secured in place, meaning that the stud will not turn, back out, or loosen in any manner when tightening or loosening the associated nuts (including cross-threaded situations).
4. When the compartment is supplied from horizontal cross-bussing, the bussing shall pass through the compartment or in the sealed area above the compartment.
5. Except for conductors supplying the instrument transformer compartment, and the ground bus, no other conductors or devices shall be installed in or routed through the compartment or the sealed area above the compartment. The ground bus shall not infringe on utility compartment space or reduce any clearances. Customer connections to the ground bus shall not be allowed in the instrument transformer compartment.
6. A clear, unobstructed work space shall be provided around the current transformer bus units from the barrier to the upper support bar.
7. Taps for attachment of meter wiring shall be provided on the neutral bus unit shown, or when the compartment is supplied from cross-bussing, a tap may be provided on the neutral cross-bus, or on a bus bar extension provided from the neutral cross-bus. A 10-32 screw and washer shall be provided for the neutral bus. Tap locations shall be centered between phase bus units, or at either side, and shall be readily accessible under energized conditions and with the current transformers in place.
8. The barrier shall be constructed of a rigid insulating material resistant to ARC tracking, and shall be secured in place with a maximum deflection of 1/2" from an applied force of 25 pounds downward. Openings in the barrier (i.e., peripheral gaps around barrier, cutouts around bus bars, and hole diameters provided for ventilation) shall not exceed 3/8". The barrier shall be attached with non- conductive fasteners.
9. The power leg bus for a 4-wire delta service shall be identified by an orange outer finish or by tagging or other effective means; yellow if B-phase (center terminal), blue if C-phase (right hand terminal) with orange tracer.
10. Dimension shall be measured to inside edge of the compartment access opening.
11. Torque labels shall be provided in each utility compartment where nut and bolt assemblies using cone-type (Belleville) washers are used for utility terminations, test-bypass block circuit-closing nuts or for securing current transformers or current transformer bus removable links. Labels shall be readily visible and shall not be installed on any removable or hinged cover panel.
12. Wall-mount application limited to 800 amps, cover panel shall be provided with two lifting handles and caution sign on the front reading "DO NOT BREAK SEAL - NO FUSES INSIDE"

	REV: Added Note 12; SRP no longer provides 3 phase 3-wire	
	METERING & SES SWITCHBOARDS, 0-600 VOLTS INSTRUMENT TRANSFORMER COMPARTMENT 3 Ø 4-WIRE SERVICE 400-1,000 AMPS	ISSUE DATE: 02/20/08 REV. DATE: 02/19/25 APPROVAL: J. Robbins
	9-19-2	ESS9-19-2.doc

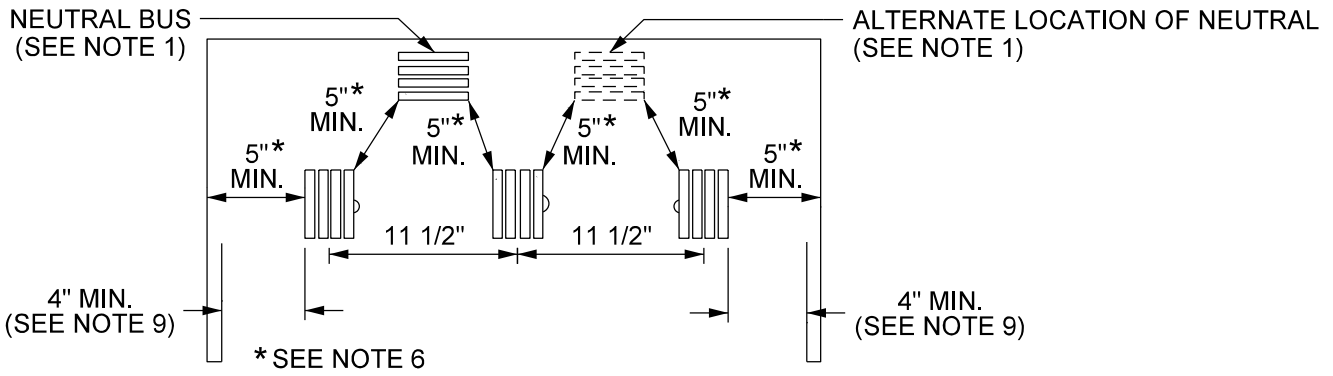

TOP VIEW

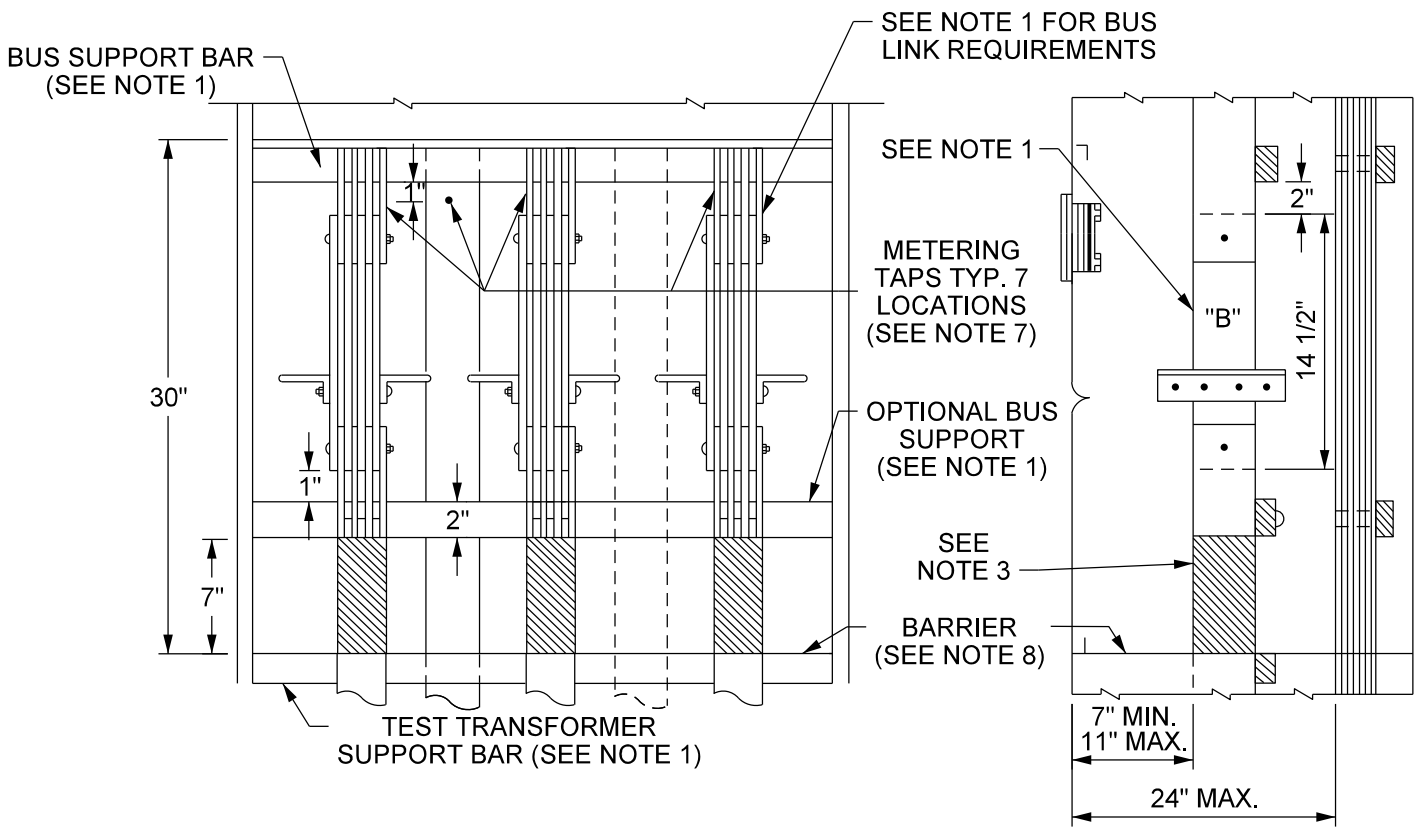

FRONT VIEW

SIDE VIEW

<p>Electric Service Specifications</p>  <p>PROPRIETARY MATERIAL</p>	<p>METERING & SES SWITCHBOARDS, 0-600 VOLTS INSTRUMENT TRANSFORMER COMPARTMENT 3Ø 4-WIRE, 1,001-3000 AMPS</p>		<p>ISSUE DATE: 03/18/08</p>
	<p>9-20-1</p>		<p>REV. DATE: 10/17/12 APPROVAL: W. Laramie 8509E279.DGN</p>

NOTES

1. Bus arrangements and supports shall be provided as shown, except the neutral bus may be located at either side or on either side wall. Bus units shall be anchored so that busses will remain in position when section "B" is removed. Bus supports shall be constructed of a continuous bar of insulating material.
2. The bus units may be supplied from the top or bottom and shall be constructed of rectangular bus. Maximum allowable bus size shall be four 1/4" x 4" bars spaced 1/4".
3. Bus units shall be insulated as shown and the insulating material shall be rated for the serving voltage. Round bus corners as necessary to prevent damage to insulation.
4. When the compartment is supplied from horizontal cross-bussing, the bussing shall pass through the compartment or in the sealed area above the compartment.
5. Except for conductors supplying the instrument transformer compartment, and the ground bus, no other conductors or devices shall be installed in or routed through, the compartment or the sealed area above the compartment. The ground bus shall not infringe on utility compartment space or reduce any clearances. Customer connections to the ground bus shall not be allowed in the instrument transformer compartment.
6. A clear, unobstructed work space shall be provided around the current transformer bus units from the barrier to 2" above the removable current transformer bus sections ("B").
7. A 10-32 tap for attachment of meter wiring shall be provided as follows:
 - A. One tap on each upper and lower phase bus unit with a 10-32 screw and washer provided for each phase bus in either the upper or lower position.
 - B. One tap on the neutral bus as shown, or when the compartment is supplied from cross-bussing, a tap may be provided on the neutral cross-bus or on a bus bar extension provided from the neutral cross bus. A 10-32 screw and washer shall be provided for the neutral bus. Tap locations shall be centered between phase bus units, or at either side, and shall be readily accessible under energized conditions and with the current transformers in place.
8. The barrier shall be constructed of a rigid insulating material resistant to ARC tracking and shall be secured in place with a maximum deflection of 1/2" from an applied force of 25 pounds downward. Openings in the barrier (i.e., peripheral gaps around barrier, cutouts around bus bars, and hole diameters provided for ventilation) shall not exceed 3/8". The barrier shall be attached with non-conductive fasteners.
9. Dimension shall be measured to inside edge of compartment access opening.
10. For bus requirements:
 - 4 inch, refer to Switchboards, 0-600 Volts Current Transformer Compartment with 4" Bus, Removable Link & Current Transformer Support.
 - 5 inch, refer to Switchboards, 0-600 Volts Current Transformer Compartment with 5" Bus, Removable Link & Current Transformer Support.

	METERING & SES SWITCHBOARDS, 0-600 VOLTS INSTRUMENT TRANSFORMER COMPARTMENT 3 Ø 4-WIRE, 1,001 – 3,000 AMPS	ISSUE DATE: 06/05/08 REV. DATE: 10/19/12 APPROVAL: W. Laramie
	9-20-2	ESS9-20-2.doc

NEUTRAL BUS
(SEE NOTE 1)

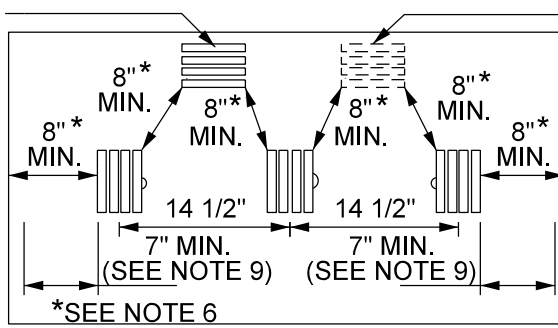

TOP VIEW

ALTERNATE LOCATION OF
NEUTRAL (OR GROUNDING BUS)
(SEE NOTE 1)

TABLE 1

MAXIMUM ALLOWABLE BUS SIZES			
FOUR	1/4" X 4"	BARS SPACED	1/4"
FIVE	3/8" X 5"	BARS SPACED	3/8"
SIX	1/4" X 5"	BARS SPACED	1/4"

BUS SUPPORT BAR
(SEE NOTE 1)

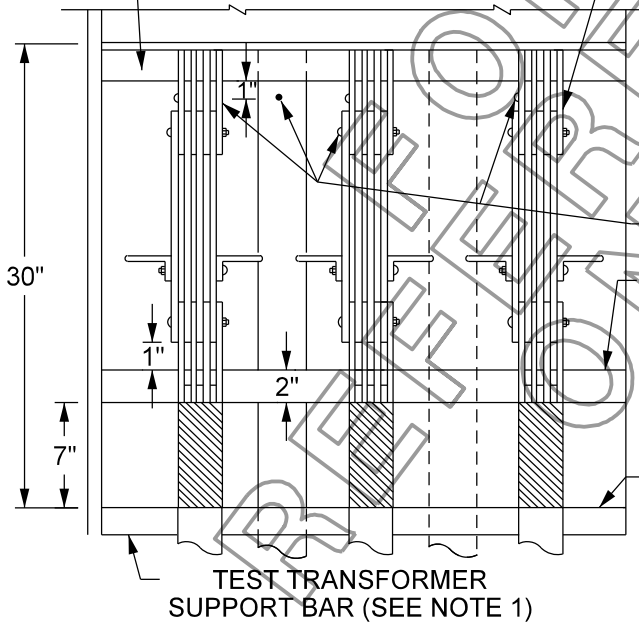

FRONT VIEW

SEE NOTE 1 FOR BUS
LINK REQUIREMENTS

SEE NOTE 1

METERING
TAPS TYP. 7
LOCATIONS
(SEE NOTE 7)

OPTIONAL BUS
SUPPORT
(SEE NOTE 1)

SEE
NOTE 3

BARRIER
(SEE NOTE 8)

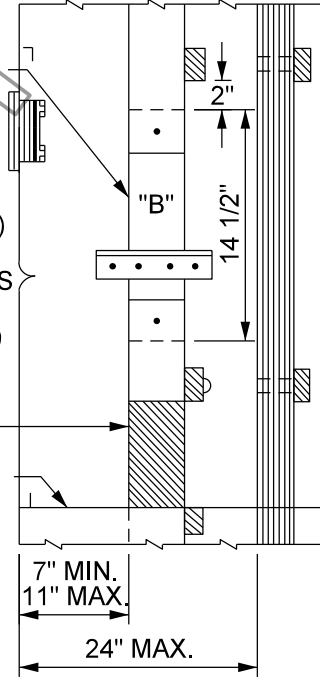

SIDE VIEW

Electric Service
Specifications



PROPRIETARY MATERIAL

REV: Added For Reference Only, applies to existing services above 3,000 A

METERING & SES
SWITCHBOARDS, 0-600 VOLTS
INSTRUMENT TRANSFORMER COMPARTMENT
3Ø 4-WIRE, 3,001 AMPS & LARGER

9-21-1

ISSUE DATE: 02/20/08

REV. DATE: 07/19/24

APPROVAL: J. Robbins

8509E280.DGN

NOTES

1. Bus arrangements and supports shall be provided as shown, except the neutral bus may be located at either side or on either side wall. (neutral bus is not required for 3 Ø, 3-wire service). Bus units shall be anchored so that busses will remain in position when section "B" is removed. Consult serving agency for the use of bus larger than 5". Bus supports shall be constructed of a continuous bar of insulating material.
2. The bus units may be supplied from the top or bottom and shall be constructed of rectangular bus. For maximum allowable bus sizes, see Table 1 on the previous page.
3. Bus units shall be insulated as shown and the insulating material shall be rated for the serving voltage. round bus corners as necessary to prevent damage to insulation.
4. When the compartment is supplied from horizontal cross-bussing, the bussing shall pass through the compartment or in the sealed area above the compartment.
5. Except for conductors supplying the instrument transformer compartment and the ground bus, no other conductors or devices shall be installed in or routed through the compartment or the sealed area above the compartment. The ground bus shall not infringe on utility compartment space or reduce any clearances. Customer connections to the ground bus shall not be allowed in the instrument transformer compartment.
6. A clear, unobstructed work space shall be provided around the current transformer bus units from the barrier to 2" above the removable current transformer bus sections ("B").
7. A 10-32 tap for attachment of meter wiring shall be provided as follows:
 - A. One tap on each upper and lower phase bus unit with a 10-32 screw and washer provided for each phase bus in either the upper or lower position.
 - B. One tap on the neutral bus as shown, or when the compartment is supplied from cross-bussing, a tap may be provided on the neutral cross-bus or on a bus bar extension provided from the neutral cross bus. A 10-32 screw and washer shall be provided for the neutral bus. Tap locations shall be centered between phase bus units, or at either side, and shall be readily accessible under energized conditions and with the current transformers in place.
8. The barrier shall be constructed of a rigid insulating material resistant to arc tracking and shall be secured in place with a maximum deflection of 1/2" from an applied force of 25 pounds downward. Openings in the barrier (i.e., peripheral gaps around barrier, cutouts around bus bars, and hole diameters provided for ventilation) shall not exceed 3/8". The barrier shall be attached with non-conductive fasteners.
9. Dimension shall be measured to inside edge of compartment access opening.
10. For bus requirements:
 - 4 inch, refer to Switchboards, 0-600 Volts Current Transformer Compartment with 4" Bus, Removable Link & Current Transformer Support.
 - 5 inch, refer to Switchboards, 0-600 Volts Current Transformer Compartment with 5" Bus, Removable Link & Current Transformer Support.

	REV: Added For Reference Only, applies to existing services above 3,000 A	
	METERING & SES SWITCHBOARDS, 0-600 VOLTS INSTRUMENT TRANSFORMER COMPARTMENT 3 Ø 4-WIRE, 3,001 AMPS & LARGER	ISSUE DATE: 06/05/08 REV. DATE: 07/19/24 APPROVAL: J. Robbins
	9-21-2	ESS9-21-2.doc

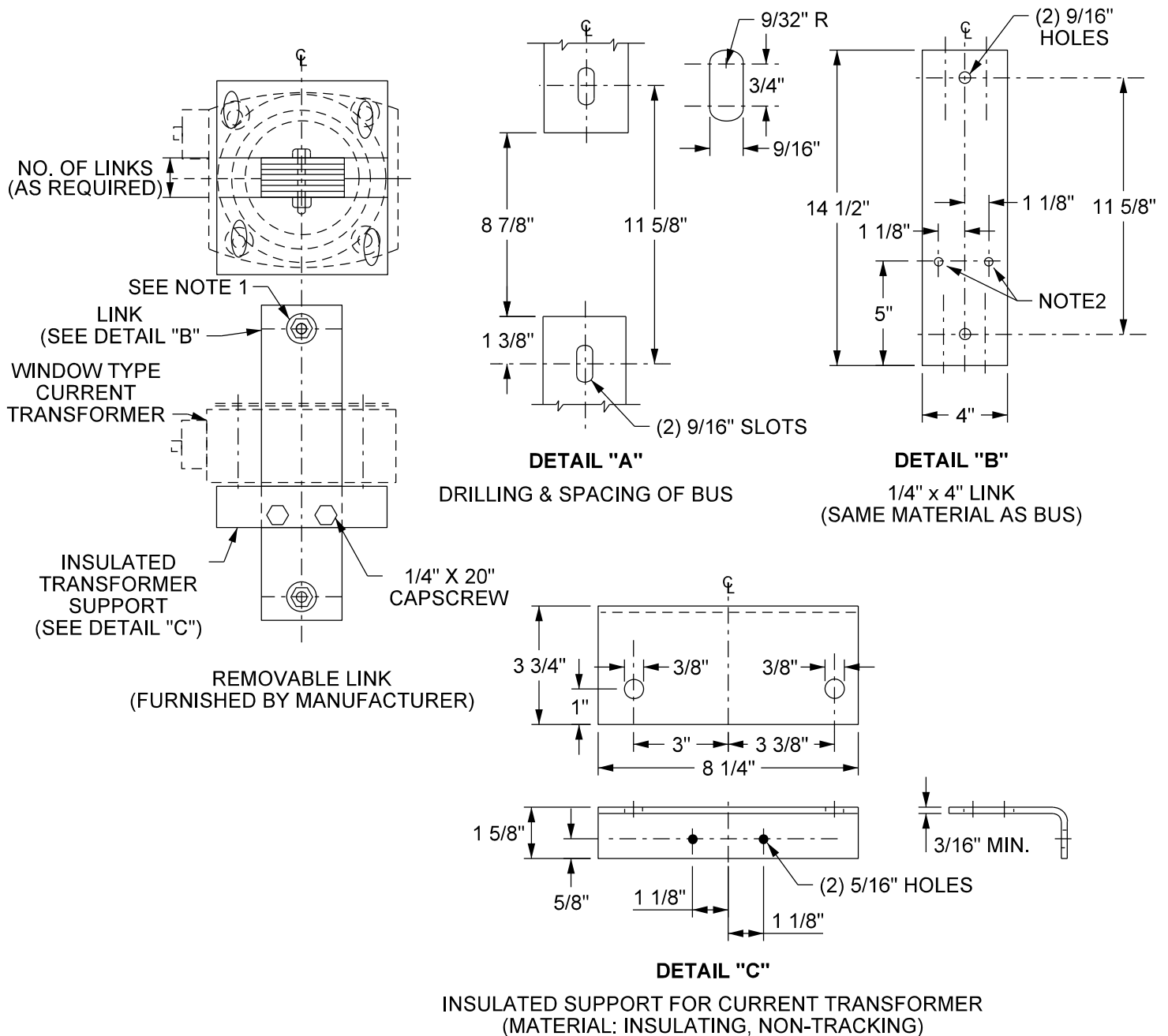

NOTES (Reference EUSERC Drawing 330)

1. Manufacturer to secure the removable bus link to the upper and lower current transformer bus units] using 1/2" hex head bolts, nuts (as shown) with a spring washer and a nut. The spring washer may be either a cone-type (Belleville) or a splitting washer with a flat washer. Bolts shall be grade 5 (min.) and washers (Belleville or flat) shall be a minimum of 2 1/4".
2. Drill and tap two holes (as shown) on the outer bus units for 1/4" x 20 cap screws.

<p>Electric Service Specifications</p>  <p>PROPRIETARY MATERIAL</p>	<p>METERING & SES - SWITCHBOARDS, 0-600 VOLTS CURRENT TRANSFORMER COMPARTMENT WITH 4" BUS, REMOVABLE LINK & CURRENT TRANSFORMER SUPPORT</p>	<p>ISSUE DATE: 01/30/94</p> <p>REV. DATE: 10/17/12</p> <p>APPROVAL: W. Laramie</p>
	<p>9-22-1</p>	<p>8509E145.DGN</p>

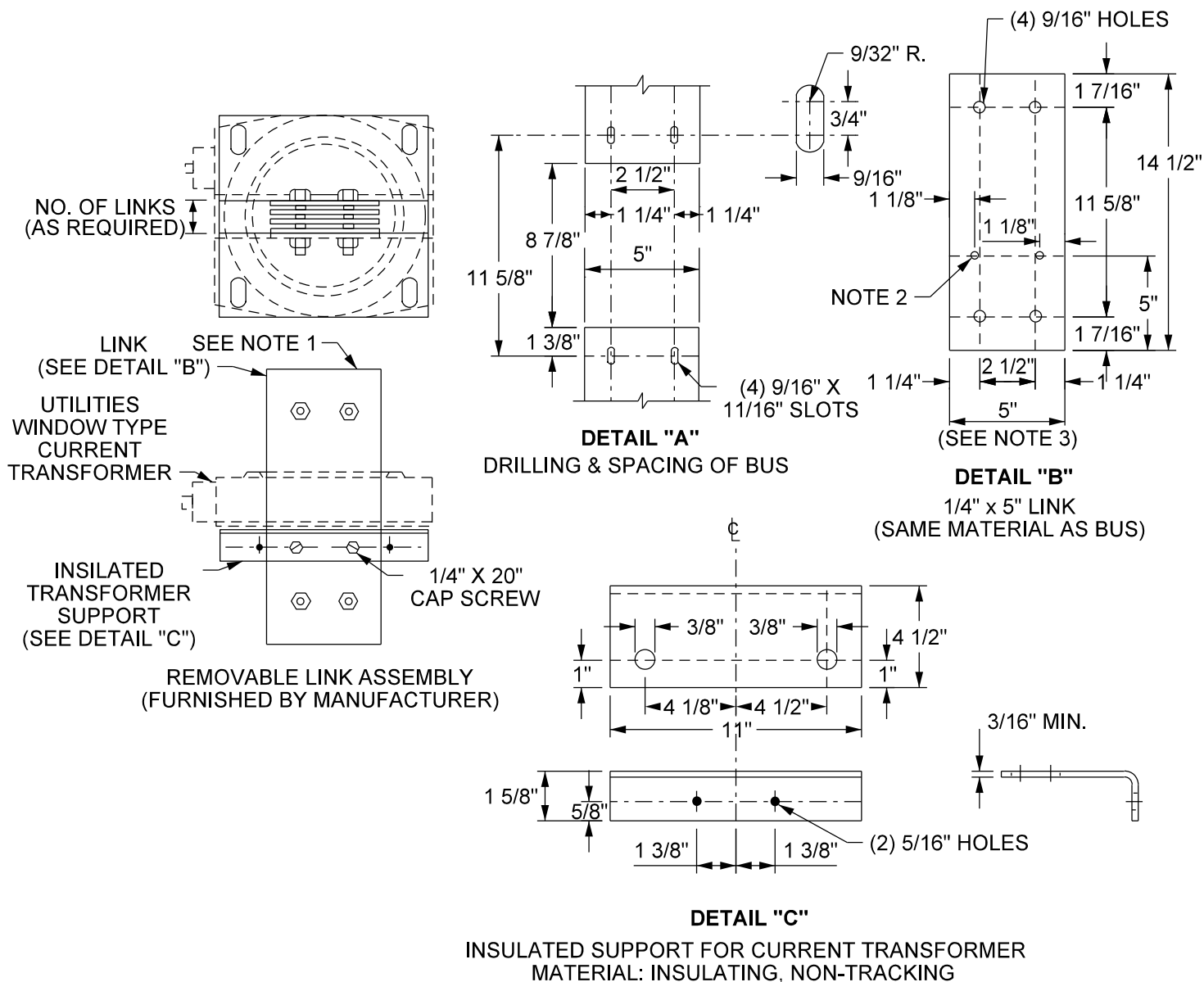

NOTES (Reference EUSERC Drawing 331)

1. Manufacturer to secure the removable bus link to the upper and lower current transformer bus units using 1/2" hex head bolts, nuts (as shown) with a spring washer and a nut. The spring washer may be either a cone-type (Belleville) or a splitting washer with a flat washer. Bolts shall be grade 5 (min.) and washers (Belleville or flat) shall be a minimum of 2 1/4".
2. Drill and tap two holes as shown on the outer bus units for 1/4" x 20 cap screws.
3. Consult the serving agency for use of bus bars larger than 5".

<p>Electric Service Specifications</p>  <p>PROPRIETARY MATERIAL</p>	<p>METERING & SES - SWITCHBOARDS, 0-600 VOLTS CURRENT TRANSFORMER COMPARTMENT WITH 5" BUS, REMOVABLE LINK & CURRENT TRANSFORMER SUPPORT</p>	<p>ISSUE DATE: 01/30/94</p> <p>REV. DATE: 10/17/12</p> <p>APPROVAL: W. Laramie</p>
	<p>9-23-1</p>	<p>8509E147.DGN</p>

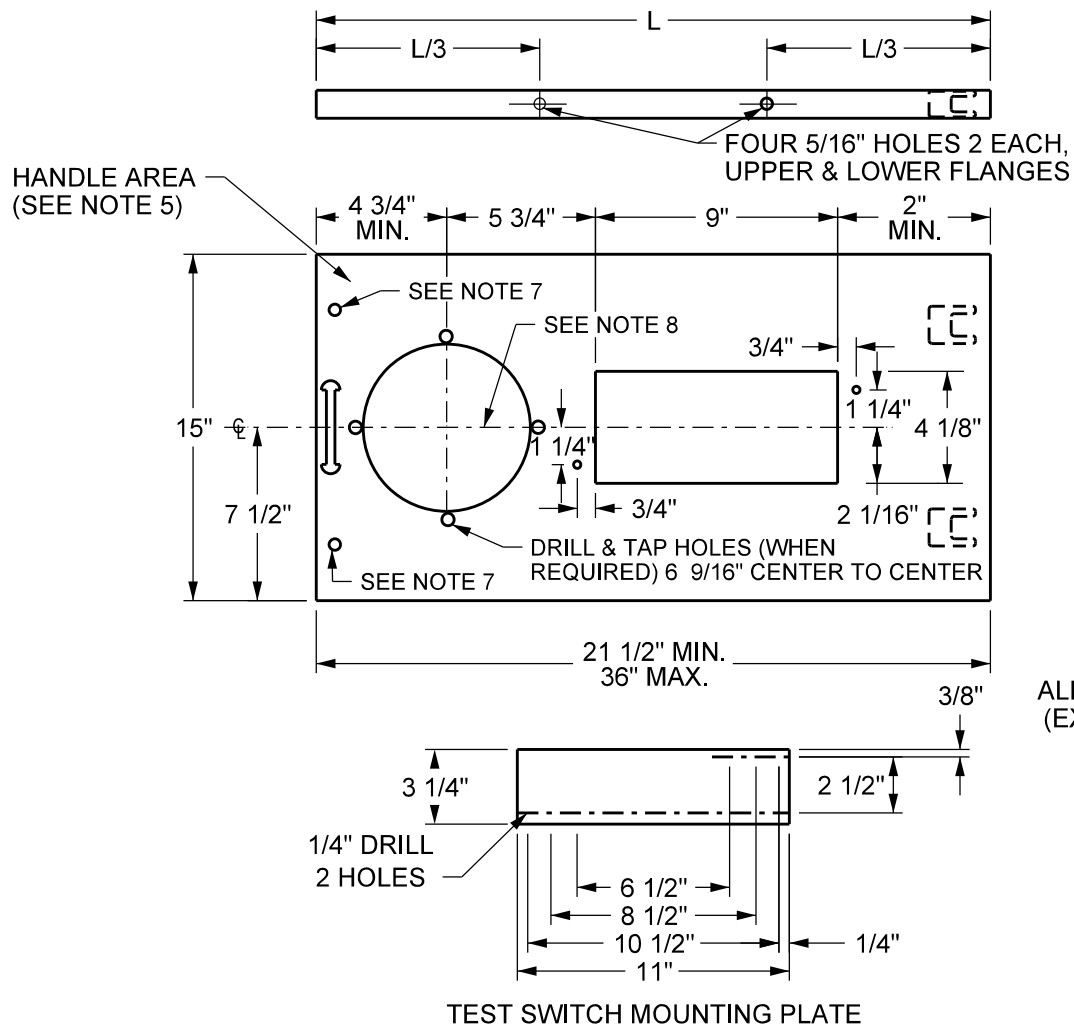

ALL HOLES 10-32 TAP (EXCEPT AS NOTED)

NOTES (Reference EUSERC Drawing 332)

1. Construct panel of 12 gauge (min.) steel and furnished with a meter socket, sealing ring and a slotted opening and removable plate for the installation of a secondary test switch. The slotted opening and removable plate edges shall be smooth to prevent damage to meter wiring.
2. The removable plate shall be attached to the rear of the panel with screws that do not protrude through the face of the panel.
3. The meter socket shall be designed for back connection.
4. The panel shall be equipped with hinges. The hinges shall permit the panel to open to 90 and shall be readily interchangeable, right or left, on the meter socket panel. For clevis or removable pin-type hinges, the pin shall be removable from the top.
5. The panel shall be equipped with a handle on the unsupported end. The handle shall be interchangeable, right or left, on the meter socket panel and maintain a minimum of 1" clearance from the meter socket flange and slotted opening.
6. The panel shall support a 25-pound load applied at the unsupported end when fully opened with a maximum sag of 1/8".
7. Stud and wing nut assemblies shall be sealable.
8. Socket diameters to meet ANSI Spec. #C12.7 (5.992" - 6.25").

<p>Electric Service Specifications</p>  <p>PROPRIETARY MATERIAL</p>	<p>METERING & SES SWITCHBOARD, 0-600 VOLTS 15 INCH HINGED METER PANEL</p>	<p>ISSUE DATE: 03/03/97</p>
	<p>9-24-1</p>	<p>REV. DATE: 10/17/12</p> <p>APPROVAL: W. Laramie</p> <p>8509E99.DGN</p>

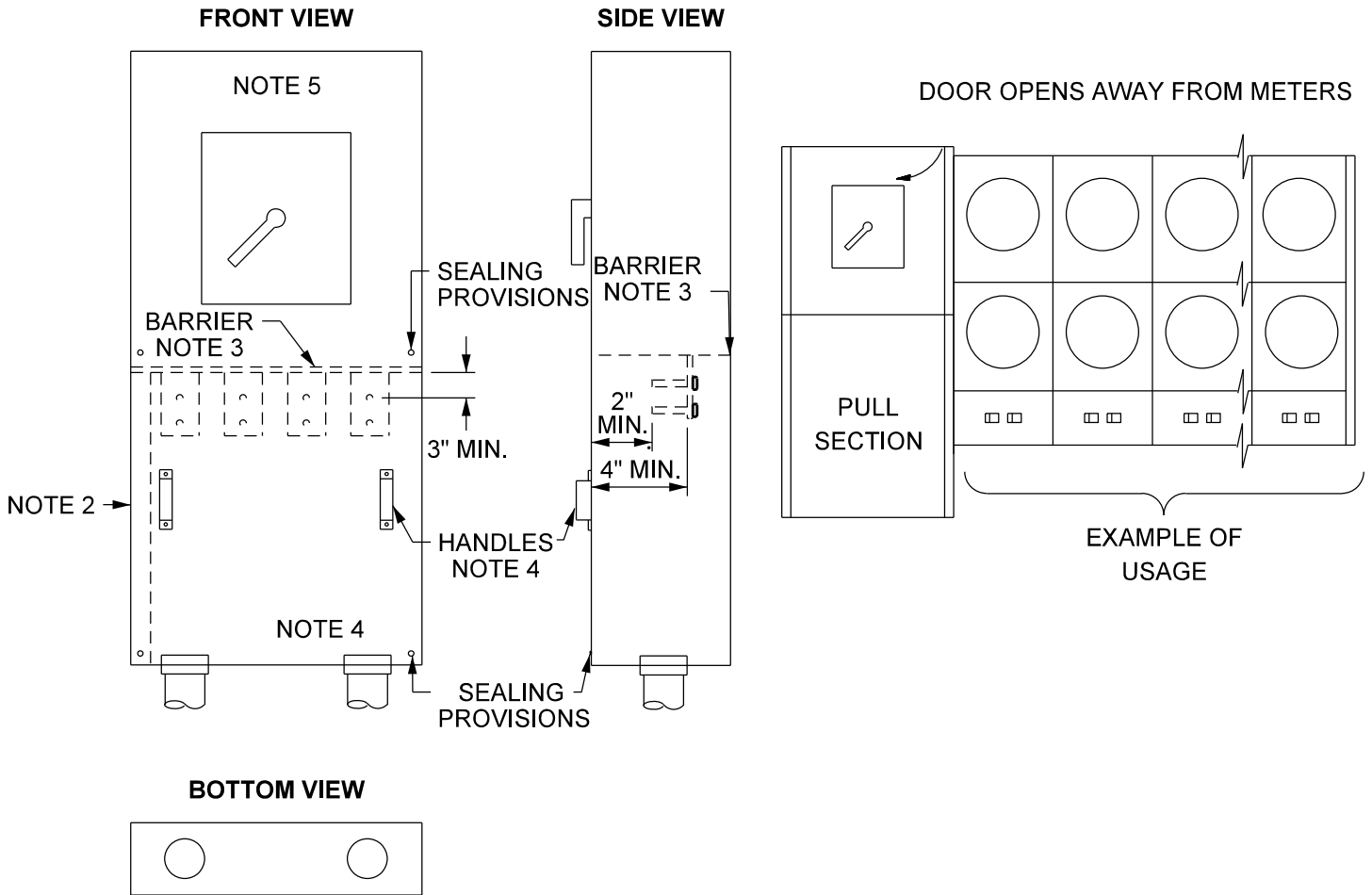

NOTES (Reference EUSERC Drawing 332)

1. A vertical clearance of 3" minimum shall be maintained between the centerline of the top bolts of the terminating facilities to any obstruction. For terminating enclosure dimensions, terminating facility clearances, and construction details refer to Section 3 - Multiple Metering Installation and Clearance, Section 9 - Commercial and Residential Use Underground Pull Section 1200 Amps Maximum, and Section 9 - Terminating Facilities Underground Pull Boxes or Pull Sections.
2. The grounding electrode conductor may be installed in a fully enclosed, factory-installed wire way located in either back corner of the pull box. The raceway shall not impede the serving utility's required working space or reduce any specified clearances.
3. A full width and depth, insulated, rigid barrier shall be provided to separate the termination and main disconnect device compartments.
4. Terminating enclosure covers shall be:
 - A. Independent of other equipment and removable without disturbing adjacent panels.
 - B. Sealable and provided with two lifting handles and limited to nine square feet in area, maximum.
5. The main disconnect cover shall be sealable.

<p>Electric Service Specifications</p>  <p>PROPRIETARY MATERIAL</p>	REV: Updated title block description	
	<p>METERING & SES COMBINATION DISCONNECTING DEVICE AND TERMINATING ENCLOSURE 1200 AMPS MAX., 0-600 VOLTS</p>	<p>ISSUE DATE: 10/20/00 REV. DATE: 01/29/19 APPROVAL: N. Sabbah</p>
	9-25-1	8509E386.DGN

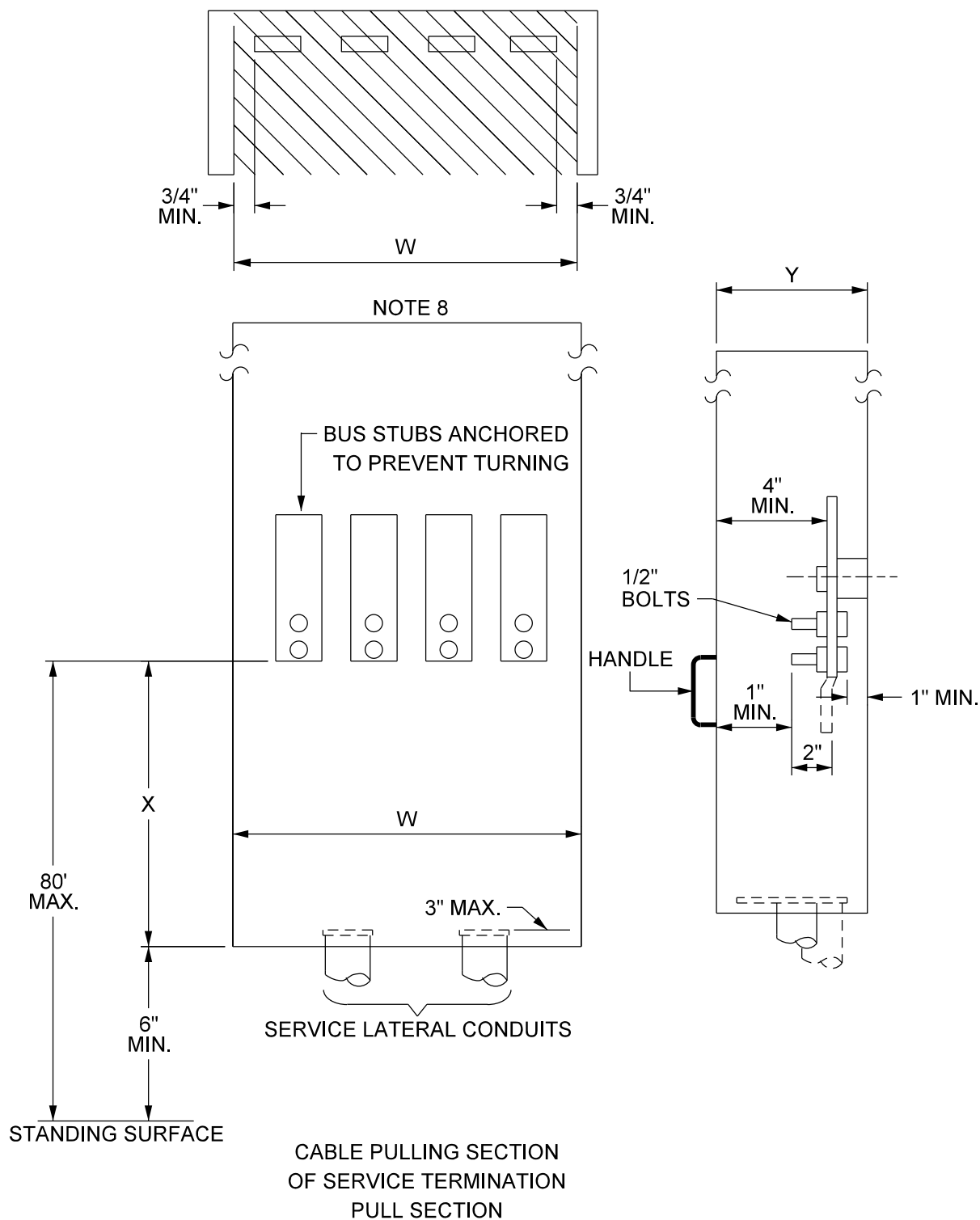

(REFERENCE EUSERC DRAWING 343)

<p>Electric Service Specifications</p>  <p>PROPRIETARY MATERIAL</p>	<p>REV: Updated title block description and note call out</p>	
	<p>METERING & SES COMMERCIAL AND RESIDENTIAL USE UNDERGROUND PULL SECTION 1200 AMPS MAXIMUM</p>	<p>ISSUE DATE: 9/18/90 REV. DATE: 01/29/19 APPROVAL: N. Sabbah</p>
<p>9-26-1</p>		<p>8509E76.DGN</p>

Minimum Pull Section Dimension

Service Ampacity	"W" Width (Opening)		"Y" Depth	"X" Lug Space
	Three-Wire	Four-Wire		
0-200	10 ½"	14"	6"	11"
201-400	10 ½"	14"	6"	22"
401-800	16 ½"	22"	11"	26"
801-1200	-	46 ½"	11"	26"

NOTES

1. The above minimum dimensions are for the conduit entering the bottom of the pull section. All load conductors exit above the terminals. Where the service conduit enters from the side or back of the pull section, the "x" dimension shall be taken from the closest portion of the nearest termination bolt. Service ampacity greater than 800 A for 120/208 V, multi-metered, wall-mounted SES serving residential load only (see Section 1 – Character of Service Limitations).
2. For termination bus and bolt details refer to Section 9 – Terminating Facilities Underground Pull Boxes or Pull Sections.
3. Provide two lifting handles on pull section covers.
4. Pull section covers shall be provided with a means of sealing consisting of two drilled stud and wing nut assemblies on opposite sides of the panel.
5. The pull section cover shall be independent of any service equipment other than the pull section.
6. Pull sections shall not be used as a j-box, refer to Section 3 – Gutter Systems, 800 Amp Max.
7. Not to exceed six meters and/or disconnects.
8. The minimum pull section access opening ("w") is measured between the left side and the right side return flanges.
9. Submit electronic copies of the plans (PDF format preferred) for all proposed SES to shopdraw@srpnet.com, for approval prior to construction of the service section. Drawings must be labeled with the Customer's name, job address, SRP job number or account number, and contractor's name and contact phone number.

 Electric Service Specifications PROPRIETARY MATERIAL	REV: Added 1200 Amp dimensions and requirements	
	METERING & SES COMMERCIAL AND RESIDENTIAL USE UNDERGROUND PULL SECTION 1,200 AMPS MAXIMUM	
	9-26-2	ISSUE DATE: 09/18/90 REV. DATE: 01/29/19 APPROVAL: N. Sabbah
		ESS9-26-2.doc

TOP VIEW

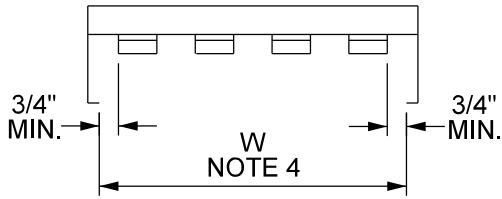

DETAIL VIEW
MECHANICAL LUG ARRANGEMENT
FOR TERMINATING FACILITIES

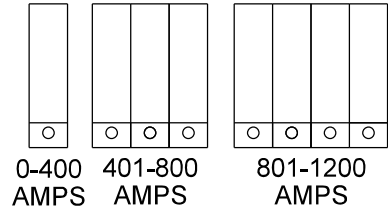

FRONT VIEW

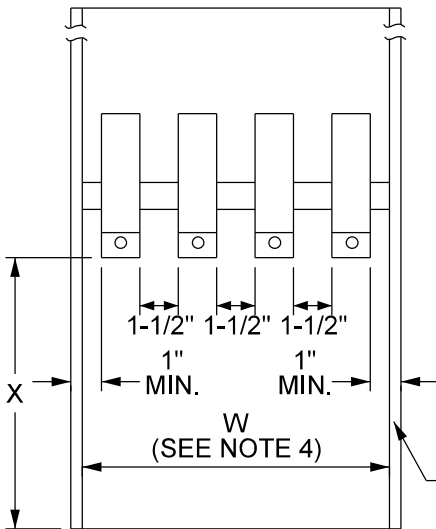

SIDE VIEW

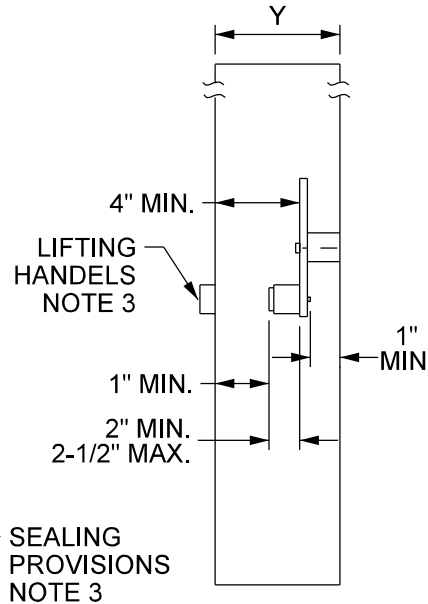

MINIMUM PULL SECTION DIMENSIONS				
SERVICE AMPACITY	"W" WIDTH (OPENING)		"Y" DEPTH	"X" LUG SPACE
	3-WIRE	4-WIRE		
0-200	10 1/2"	14"	6"	11"
201-400	10 1/2"	14"	6"	22"
401-800	16 1/2"	22"	11"	26"
801-1200	N/A	30"	11"	26"

NOTES (Reference EUSERC drawing 343A)

1. Terminating facilities for service supply conductors shall be aluminum-bodied mechanical lugs with a range accepting No. 4 AWG through 750 kcmil conductor. Provide one lug for terminations rated up to 400 amps, three lugs for terminations rated 401-800 amps, and four lugs for terminations rated 801- 1200 amps (120/208 V multi-metered wall mounted SES serving residential load only, see Section 1 - Character of Service Limitations).
2. Secure terminating facilities to prevent turning or bus misalignment when the cables are installed.
3. Pull section covers shall be removable and provided with a means of sealing consisting of two drill stud and wing nut assemblies on opposite sides of the cover and provided with two lifting handles and limited to a maximum area of 9 square feet.
4. Measure the minimum pull section access opening ("W") between the left side and right side return flanges.
5. Submit electronic copies of the plans (PDF format preferred) for all proposed SES to shopdraw@srpnet.com for approval prior to construction of the service section. drawings must be labeled with the customer's name, job address, SRP job number or account number, and contractor's name and contact phone number.
6. Do not use a pull section as a j-box.
7. Do not exceed six meters and/or disconnects.

	REV: Update to align with EUSERC 343A	ISSUE DATE: 12/20/00
	<p align="center">METERING & SES WALL-MOUNTED PULL SECTION WITH CABLE TERMINATING FACILITIES (MECHANICAL LUGS) 1-600 VOLTS, 1200 AMPS MAXIMUM</p>	REV. DATE: 05/23/24
	<p align="center">9-27-1</p>	APPROVAL: J. Robbins 8509E385.DGN

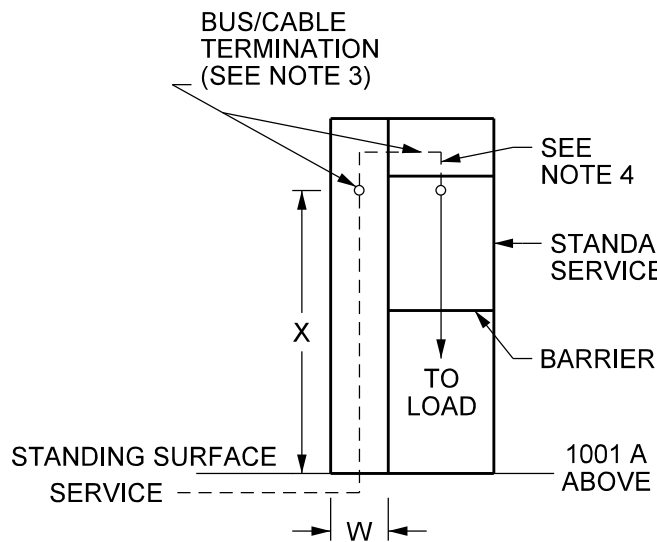

FIG.1
SWITCHBOARD PULL SECTION

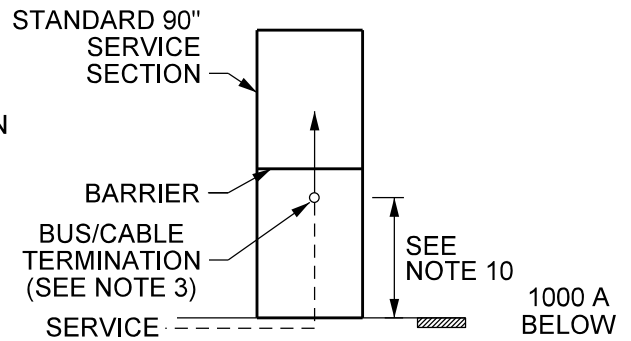
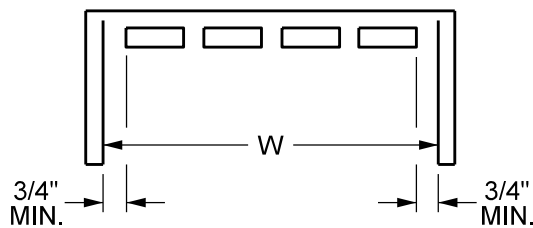

FIG.2
BOTTOM FEED
400-1000 AMPS



BUS BAR DETAIL

TABLE 1-MINIMUM PULL SECTION DIMENSIONS			
SWITCHBOARD RATING-AMPS	MINIMUM WIDTH "W"		MIN. "X" DIMENSION
	3-WIRE	4-WIRE	
BELOW 400	CONSULT SRP		
400-800	24"	24"	42" MIN. *-72" MAX.
801-1,000	24"	30"	
1,001-2,000	30"	35"	60" MIN.-72" MAX.
2,001-3,000	-	42"	
3,001-4,000**	-	44"	

* FOR REDUCED TERMINATION HEIGHT IN BOTTOM-FED SERVICE SECTIONS, REFER TO SECTION 9 - SWITCHBOARDS COMBINATION PULL SECTION 1,000 A MAX.
 ** REFERENCE TO ONLY EXISTING SES LARGER THAN 3,000 A.

REFERENCE EUSERC DRAWING 345

<p>Electric Service Specifications</p>  <p>PROPRIETARY MATERIAL</p>	REV: Add table reference, only applicable to existing SES	
	<p>METERING & SES SWITCHBOARD PULL SECTION</p>	
	<p>9-28-1</p>	
	<p>ISSUE DATE: 09/18/90 REV. DATE: 07/19/24 APPROVAL: J. Robbins</p>	
		8509E77.DGN

NOTES

1. A switchboard pull section (Fig. 1) or a reverse feed service section (Fig. 2) shall be provided for underground service.
2. When the service section is served from a pull section, the bus or cable conductors shall enter through the side or back of the sealable section above the current transformer compartment (as shown in Fig. 1) or shall enter by means of horizontal cross bussing in back of metering compartment.
3. **Rating above 800 amps or when multiple metering is to be supplied:** Bus bars with provisions for termination lugs (refer to Sections 9 – Terminating Facilities Underground Pull Boxes or Pull Sections) are required from the pull section into the service section.
4. **Rating up to 800 amps:** Termination lugs are required in the pull section. The connection from the termination lugs to the service section can be made by either:
 - A. Install cables up and into the service section, cables provided by customer.
 - B. Install bus bar to the service section.
5. The minimum width of the pull section opening shall be as specified in table 1. For arrangement of the cable terminating facilities in the pull section refer to Section 9 – Terminating Facilities Underground Pull Boxes or Pull Sections.
6. Side or rear entry of the service cable into the pull section may require a greater dimension than that shown in table 1; consult SRP.
7. Consult SRP for the type and size of terminating lugs.
8. All pull and terminating sections shall have full front access. Cover panels shall be removable, sealable, provided with two lifting handles and limited to a maximum size of 9 square feet in area.
9. Sealing provisions shall consist of two drilled stud and wingnut assemblies on opposite sides of the panel.
10. Clearance from bus/cable termination to bottom of cabinet, refer to Section 9 – Switchboards Combination Pull Section 1,000 A Max.

	REV: Add Note 4A & 4B and enhance the clarity of Notes 3 & 4	
	METERING & SES SWITCHBOARD PULL SECTION	ISSUE DATE: 09/18/90 REV. DATE: 11/14/24 APPROVAL: J. Robbins
	9-28-2	ESS9-28-2.doc

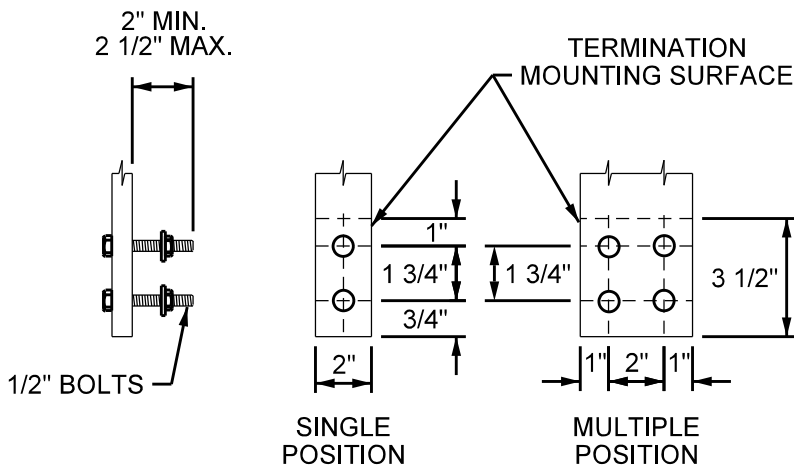

FIG. 1 TERMINATING BOLT AND DRILLING DETAIL OF TERMINATING FACILITIES

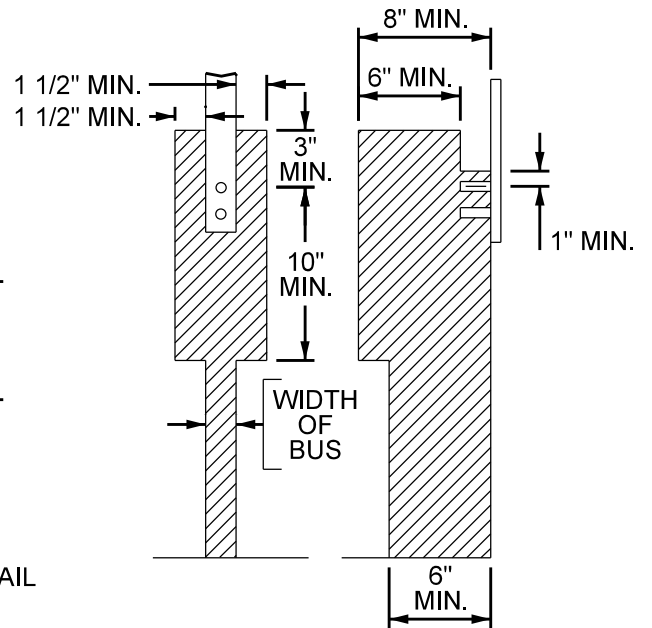
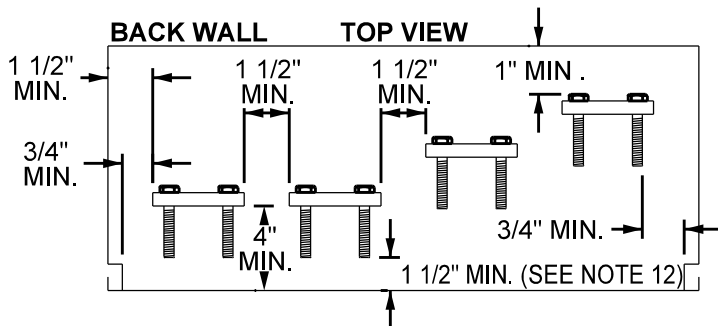

FIG. 4 REQUIRED UNOBSTRUCTED WORKING SPACE FOR ALL TERMINATIONS



REMOVABLE FRONT COVER PANEL
FIG. 2 SPACING REQUIREMENTS FOR TERMINATING FACILITIES (SIDE BY SIDE OR STAGGERED)

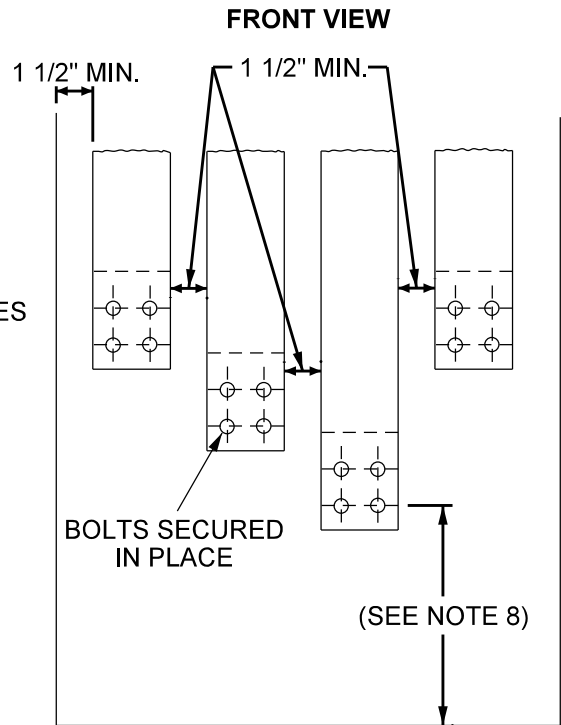

FIG. 5 SPACING REQUIREMENTS FOR TOP TO BOTTOM STAGGER OF TERMINATING FACILITIES

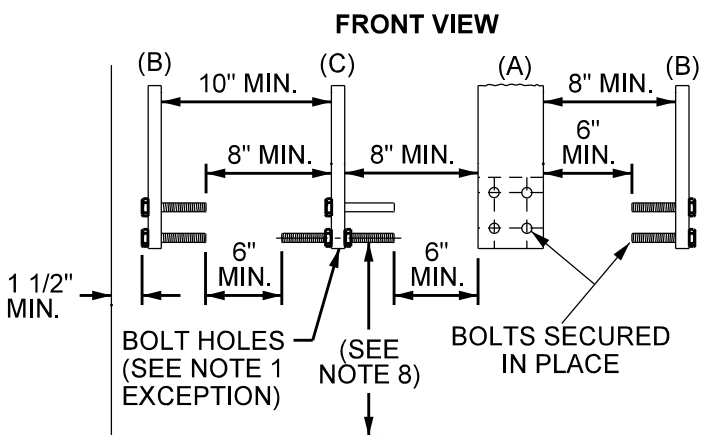



FIG. 3 SPACING REQUIREMENTS FOR TERMINATING FACILITIES ACCESSIBLE FROM (A) FRONT ONLY, (B) ONE SIDE ONLY, OR (C) FROM EITHER SIDE

Reference EUSERC Drawing 347.

<p>Electric Service Specifications</p>  <p>PROPRIETARY MATERIAL</p>	<p>METERING & SES TERMINATING FACILITIES UNDERGROUND PULL BOXES OR PULL SECTIONS</p>		<p>ISSUE DATE: 04/15/86</p>
	<p>9-29-1</p>		<p>REV. DATE: 10/17/12</p> <p>APPROVAL: W. Laramie</p> <p>8509E102.DGN</p>

NOTES

1. The number of landing positions shall be equal to the number of conduits required on page 6-2. Each landing position shall consist of two 1/2" steel bolts spaced on 1 3/4" vertical centers and extending from 2" to 2 1/2" from the mounting surface. When multiple positions are required, provide a minimum of 2" of horizontal spacing between positions.

EXCEPTION: Edgewise terminating facilities may consist of 9/16" holes having the same spacing as specified for the 1/2" bolts in Note 1 and in Figure 1. The unobstructed working space shall be provided on both sides of the termination bus (see Figure 3).

2. Each terminating bolt shall be provided with a spring washer and nut. The spring washer may be either a cone-type (Belleville) washer or a split-ring washer and a flat washer. All parts shall be plated to prevent corrosion. Terminating bolts shall not be used to secure the termination bus in place.
3. Terminating bolts must be secured in place, meaning that the stud will not turn, back out or loose in any manner when tightening or loosening terminal nuts (including cross-threaded situations).
4. In the terminal mounting area, which is defined as the area of the terminating facilities shown in Figure 1, a clear space (barrel of proximity) of 1 1/2" minimum is required around any terminating facility. This includes its bolts, bolt heads, any other bus, any other terminating facility or any grounded surface, except:
 - A. The minimum clearance to the back of the pull section may be reduced to 1".
 - B. Clearance to any fully insulated horizontal bus behind the terminating facility may be reduced to 1' minimum.
 - C. The neutral terminating facility may have a minimum clearance of 1" from any grounded surface.

5. Each terminating facility may have an unobstructed working space accessible from the front of the pull section. Figure 4 shows the view from the access compartment opening in the front of the mounting surface.

EXCEPTION: For terminating facilities with bolts facing the access opening (as shown in Figure 2), the required 1 1/2" side clearance (bus to access opening return flange) may be reduced to 3/4".

6. The clearance directly above and measured from the center of the top termination bolt may be reduced to 1" to either an insulated surface or bus of the same potential.
7. No more than one termination facility may be mounted along any sidewall.
8. For minimum distance from the lowest bolt on the termination facility to the bottom of the termination enclosure refer to Section 3 – Residential Multiple Occupancy Service Six Meters, 600 Amps Max 120-240 V Underground 1 Ø 3-Wire, Section 9 – Commercial and Residential Use Underground Pull Section 1200 Amps Maximum, Section 9 – Wall-Mounted Pull Section With Cable Terminating Facilities (Mechanical Lugs) 1-600 Volts, 1200 Amps Maximum, and Section 9 – Switchboard Pull Section..
9. Terminating facilities shall be secured to prevent turning or bus misalignment when the cables are installed.
10. The neutral terminating facility shall be permanently identified in clearly visible block lettering reading either "neutral" or "N".
11. Uninsulated busses of different potentials shall not be permitted below or behind any terminating position as viewed from front of the pull section. If cross bussing is installed below or behind a terminating position, the cross bussing shall be fully insulated or barriered.

	METERING & SES TERMINATING FACILITIES UNDERGROUND PULL BOXES OR PULL SECTIONS		ISSUE DATE: 04/15/86 REV. DATE: 11/15/12 APPROVAL: W. Laramie
	9-29-2		ESS9-29-2.doc

12. For switchboard pull sections, the minimum clearance from any energized part to a removable access cover panel shall be 4". This clearance may be reduced to 1 1/2" when the manufacturer provides a safety barrier. The safety barrier shall:
- A. Be constructed of a rigid insulating material, resistant to damage by impact or puncture, with a minimum thickness of 1/8".
 - B. Extend a minimum of 10" below terminating bus and extend upward to cover all energized parts that infringe into the 4" minimum clearance dimension, and be removable.
- NOTE: Safety barrier mounting brackets and hardware shall not extend into the provided access opening.
- C. Have a caution sign affixed to the barrier reading "WARNING:THIS BARRIER MUST BE INSTALLED BEFORE REPLACING PULL SECTION COVERS". Additional caution signs shall be affixed to exterior of each pull section access cover reading "DO NOT REPLACE PULL SECTION COVERS UNTIL SAFETY BARRIER IS IN PLACE".
 - D. Screws or bolts requiring special tools for installation or removal are not acceptable.
13. The Customer shall supply and install mechanical terminating connectors in the service section and provide the terminating connectors in the transformer when service conductor is Customer-owned. Wire size and quantity are approved by AHJ.
14. For 120/240 volt 3 Ø 4-wire delta services, the power leg shall be C Ø (measuring 208 volts to ground) and shall be marked blue with an orange tracer.

<p>Electric Service Specifications</p>  <p>PROPRIETARY MATERIAL</p>	<p>METERING & SES TERMINATING FACILITIES UNDERGROUND PULL BOXES OR PULL SECTIONS</p>	<p>ISSUE DATE: 04/15/86</p>
	<p>9-29-3</p>	<p>REV. DATE: 11/15/12</p> <p>APPROVAL: W. Laramie</p>

1. Scope

The requirements in this section apply to revenue metering compartments within indoor and outdoor metal-enclosed or metal-clad switchgear installations rated 2,400 V to 12,470 V, configured for 4-wire applications.

2. Approval

For SRP approval of switchgear and design location, refer to Section 1: General Information - Request for Service.

3. Standards Compliance

All equipment and associated designs shall comply with the latest published standards from NEMA, EUSERC, and SRP standards. In the event of a conflict between applicable standards, SRP shall determine the final outcome.

4. SRP Furnished and Installed Equipment

Current transformers, voltage transformers, meters, testing facilities, and all standard secondary wiring from the instrument transformers to the meters will be furnished and installed by SRP.

5. Basic Impulse Level (BIL) Rating

BIL for the metering enclosure shall not be less than that of the Customer's associated switchgear. For reference, refer to the latest editions of ANSI Standards C37.20.2 or C37.20.3 for minimum accepted BIL ratings for medium-voltage switchboards built to the nominal listed voltages in their respective corresponding Table 1, "Preferred Voltage and Insulation Levels for MC Switchgear," and "Preferred Voltage and Insulation Levels for MEI Switchgear." The metering cubicle shall be labeled with the BIL rating.

Rated Maximum Voltage (kV)	Power Frequency Withstand (kV rms)	Lightning Impulse Withstand (BIL-kV)
4.76	19	60
15.0	34	95

6. Current Ratings

Customer shall install a load-limiting device adjacent to the primary meter, based on the SES Sizing Limitations outlined in Section 1 – General, Character of Service and Limitations.

7. Equipment Pad and Work Space

Shall meet the requirements outlined in Section 5 – Clearances, Service Entrance Section, Work Space & Exit Route, Greater than 600 V.

	REV: Align w/ the latest EUSERC specifications & improve readability	
	METERING & SES MEDIUM VOLTAGE GENERAL REQUIREMENTS	ISSUE DATE: 04/05/86 REV. DATE: 11/14/25 APPROVAL: J. Robbins
	9-30-1	ESS9-30-1.doc

1. Utility Compartment Labeling

Permanent labels shall be machine-engraved laminated phenolic (or equal) tags having 1/4 inch white lettering on red-colored background material. Labels shall be readily visible and securely riveted to the face of the following utility compartments:

- A. Voltage transformer
- B. Voltage transformer fuse
- C. Service termination / Pull section
- D. Current transformer
- E. Meter panel
- F. Voltage and maximum current rating permitted by SRP on utility meter panel (i.e., 12,470 V, 156 A maximum).

2. Safety Grounding Provisions

Shall be equipped with a 1-inch diameter grounding knob (ball stud) on the following:

- A. Line side of the bus at each current transformer location
- B. Load side of the bus at each current transformer location
- C. Ground bus at current transformer location

3. Door Specifications

General

- A. **Weatherproofing:** All external enclosure doors shall be weatherproof.
- B. **Door Configuration:** Doors shall be hinged and capable of remaining securely open at 90 degrees or more.
- C. **Security Features for Front and Rear Door:** Doors shall be equipped with a three-point locking mechanism and a latch-type handle suitable for securing with a SRP padlock.
Exception: For indoor installations, refer to Note E.

Front Door

- D. **Inner Panel Arrangement:** The front door shall include an inner meter panel door.
- E. **Indoor Installations:** For indoor applications, outer weatherproof doors may be omitted, however, then the meter panel shall be equipped with a lockable mechanism.

Meter Panel Door

- F. **Hinge Orientation:** The meter panel door shall be hinged on the side opposite that of the outer front door hinge and meets the same *Door Configuration* requirements, allowing to remain securely open at 90 degrees.
- G. **Weight Capacity:** The door shall be designed to support 25-pound applied load at the unsupported end, with a maximum sag of 1/8 inch when open.
- H. **Ground Bonding:** A #4 AWG copper flexible braided bond wire shall be installed across the hinges.

Rear Door (CT and Terminations Compartment)

- I. **Barrier Arrangement:** The rear door shall have an inner clear barrier panel.

	REV: Align w/ the latest EUSERC specifications & improve readability	
	METERING & SES MEDIUM VOLTAGE ENCLOSURE REQUIREMENTS	ISSUE DATE: 04/05/86 REV. DATE: 11/14/25 APPROVAL: J. Robbins
	9-31-1	ESS9-31-1.doc

Clear Barrier Panel

- J. **Barrier Design:** The barrier shall be a full-height transparent polycarbonate barrier positioned between the outer door and live parts, and the barrier shall not come in contact with live parts.
- K. **Hinge Orientation:** The barrier shall be hinged on the same side as the exterior door and meets the same *Door Configuration* requirements, allowing to remain securely open at 90 degrees.
- L. **Secure Closure:** The barrier shall remain securely closed when the external door is opened.

4. Ventilation Openings

A ventilation opening-slot louver, or the like, shall be protected by one or more baffles, barriers or other obstructions of such dimensions and locations that any wire or similar material will be deflected two times after it is inserted at any possible angle through the opening or mesh. One deflection shall be at least 90° from the direction of travel. In addition, if the minor dimension of a ventilation opening is larger than 1/4 inch, it shall be protected by a screen having a minor dimension no larger than 1/4 inch.

 <p>Electric Service Specifications PROPRIETARY MATERIAL</p>	REV: Align w/ the latest EUSERC specifications & improve readability	
	METERING & SES MEDIUM VOLTAGE ENCLOSURE REQUIREMENTS	ISSUE DATE: 04/05/86 REV. DATE: 11/14/25 APPROVAL: J. Robbins
	9-31-2	ESS9-31-1.doc

1. Approved Bus Material

Only copper or plated aluminum bus shall be used. Aluminum bus shall be plated to prevent corrosion.

2. Bus Dimensions and Spacing

Maximum bus size shall be 3/8 x 4 inches. Minimum bus size shall be 1/4 x 2 inches unless otherwise indicated on specific drawing. Bus sizes outside of these limits require special engineering and consultation with SRP.

3. Conductors Passing Through Compartment Walls

Where cable or bus passes through compartment walls, through-the-wall bushings with full voltage rating of the switchboard must be used.

4. Service Cable Terminations

One landing position (two 1/2-inch steel bolts on 1 3/4-inch vertical centers extending a minimum of two inches to a maximum of 2 1/2 inches from the mounting surface) shall be provided on each phase and neutral bus. Secure all bolts in place and provide with nuts, flat washers and pressure maintaining spring washers. "Secured in Place" shall mean that the stud will not turn, back out or loosen in any manner when subjected to normal UL-approved torque while tightening or loosening terminal nuts (including cross threaded situations). All parts must be plated to prevent corrosion.

5. Insulated Neutral Termination

An insulated neutral is required and shall have full voltage-rated insulation from the metering cubicle. The insulated neutral shall extend from the CT compartment to the VT compartment and Customer's disconnect section before grounding. The main bonding jumper shall be made in the Customer section.

6. Instrument Transformer Mounting Bases and Bus Links

Voltage and current transformer mounting bases are to be provided by the manufacturer. Locate the front or leading edge of the voltage transformer mounting holes nine inches from the voltage transformer compartment door. Bus drilling and spacing shall accommodate 800 amperes or less current transformers of the proper voltage insulation class. Lugs for voltage transformer phase and neutral connections shall be provided in the voltage transformer compartment.

7. Fuse Specification

Voltage transformer fuses shall be furnished and installed by the serving agency. The manufacturer shall provide mounting clips for indoor current limiting fuses with mounting clip separation and fuse ferrule diameter dimensions as indicated under dimension "H".

8. Voltage Transformer Isolation/Ground Switch and Compartment Requirements

- A. Kirk Key interlocking is required between the voltage transformer (VT) isolation/ground switch and the voltage transformer compartment door, which requires the VT isolation/ground switch to be locked in the ground position before the VT compartment door can be opened, and until the VT compartment door is locked closed.
- B. Each position of all three blades must be visible through the window centered over the blades.
- C. Each switch position shall be obtained by spring action independent of the operating handle speed.

 <p>Electric Service Specifications SRP[®] PROPRIETARY MATERIAL</p>	REV: Title blocks for Medium Voltage Section	
	<p>METERING & SES MEDIUM VOLTAGE BUS & TERMINATION REQUIREMENTS</p>	<p>ISSUE DATE: 04/05/86 REV. DATE: 12/10/25 APPROVAL: J. Robbins</p>
	9-32-1	ESS9-32-1.doc

- D. The isolation/ground switch shall be rated for the applicable voltage and current interruption.
- E. The single isolation/ground switch shall de-energize, isolate, and earth ground the line side of the VT fuses in one operation using one handle.
- F. The voltage transformer compartment door shall provide unobstructed access to the voltage transformers and fuses.
- G. The line connection to the VT disconnect shall be on the line side of the CT.

9. Exposed Ends of Fasteners

Exposed ends of fasteners on doors or panels shall be smooth to limit the possibility of injury.

	REV: Title blocks for Medium Voltage Section	
	METERING & SES MEDIUM VOLTAGE BUS & TERMINATION REQUIREMENTS	ISSUE DATE: 04/05/86 REV. DATE: 12/10/25 APPROVAL: J. Robbins
	9-32-2	ESS9-32-1.doc

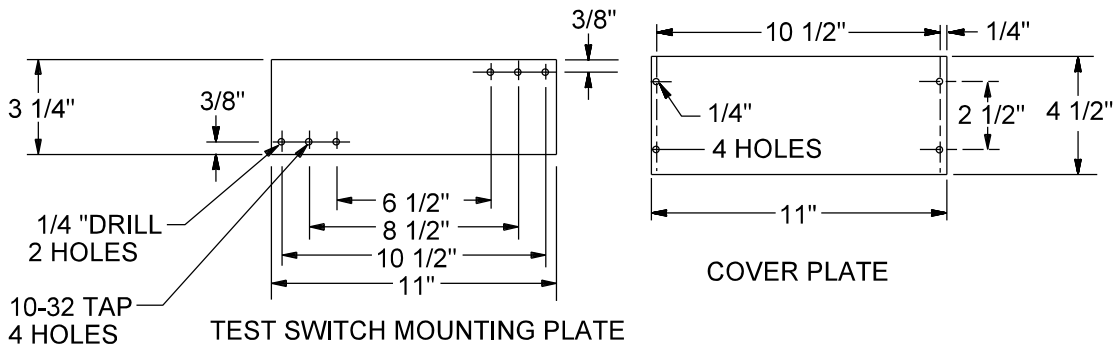
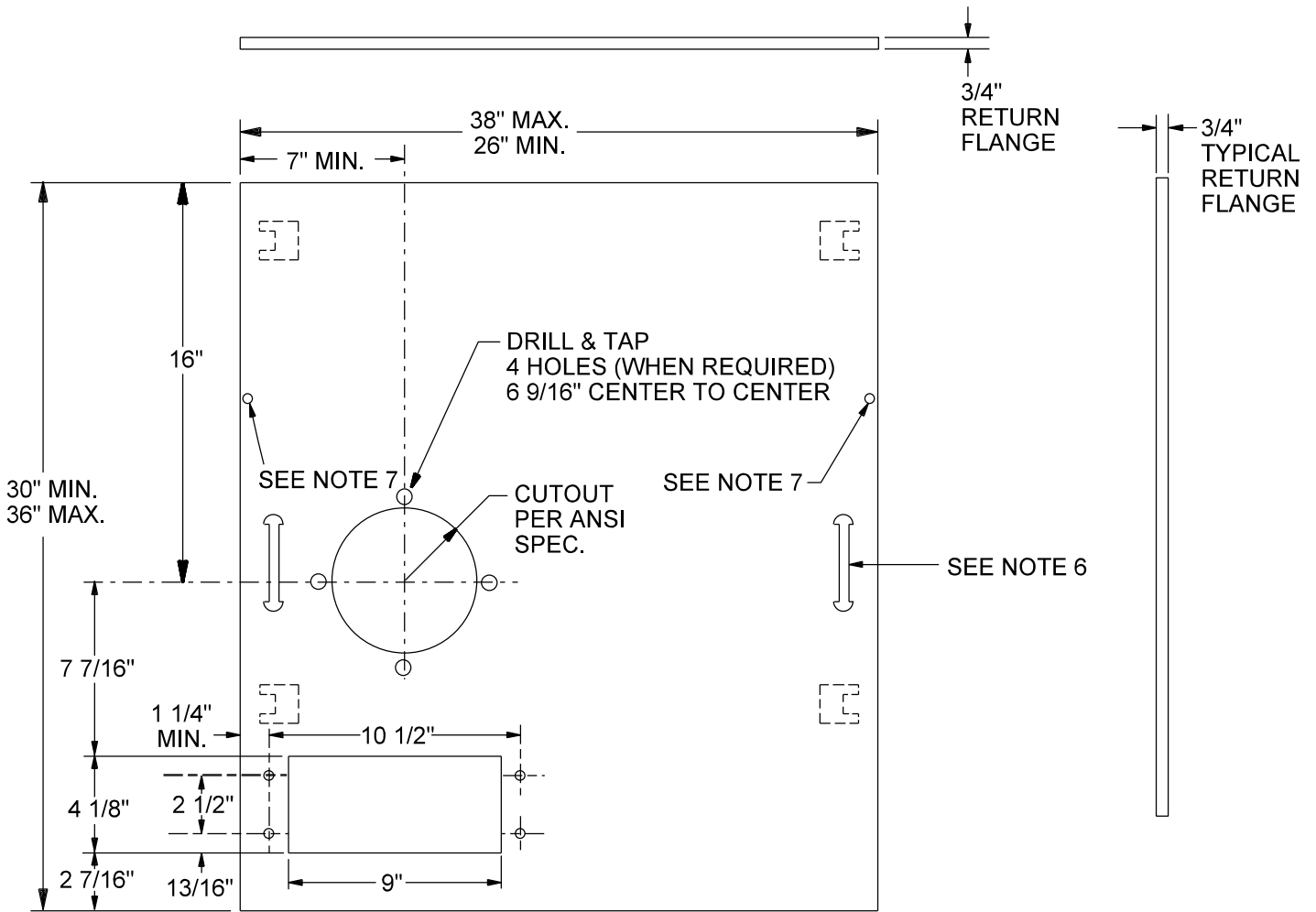

ALL HOLES 10-32 TAP EXCEPT AS NOTED.

Reference EUSERC Drawing 408.

<p>Electric Service Specifications</p>  <p>PROPRIETARY MATERIAL</p>	<p>REV: Title block update with Medium Voltage language</p>	
	<p>METERING & SES MEDIUM VOLTAGE HINGED METER PANEL WITH SINGLE SOCKET</p>	
<p>9-33-1</p>		<p>ISSUE DATE: 04/15/86 REV. DATE: 12/10/25 APPROVAL: J. Robbins 8509E106.DGN</p>

NOTES

1. Construct the panel with 12-gauge (min.) steel and furnish with meter sockets, sealing rings, slotted openings, a removable plate for installation of a secondary test switch, and a cover plate. Slotted openings and removable plate edges shall be smooth to prevent damage to meter wiring.
2. Attach the removable plates to the rear of the panel with screws that do not protrude through the face of the panel.
3. Design meter sockets for back connection.
4. Hinges shall be readily interchangeable, right or left, on panel and permit the panel to open 90° with meter and test facilities in place. For recessed or enclosed meter panels, refer to EUSERC Drawing 407. Clevis or removable pin-type hinges shall be removable from the top.
5. The panel shall support a 25-pound load applied at the unsupported end when fully opened with maximum sag of 1/8".
6. Attach a handle to both sides of the panel.
7. All securing and sealing screws on panel shall be captive. Stud and wing nuts shall be sealable when used.

 <p>Electric Service Specifications</p> <p>PROPRIETARY MATERIAL</p>	REV: Title block update with Medium Voltage language	
	METERING & SES MEDIUM VOLTAGE HINGED METER PANEL WITH SINGLE SOCKET	ISSUE DATE: 02/15/86 REV. DATE: 12/10/25 APPROVAL: J. Robbins
	9-33-2	ESS9-33-2.doc

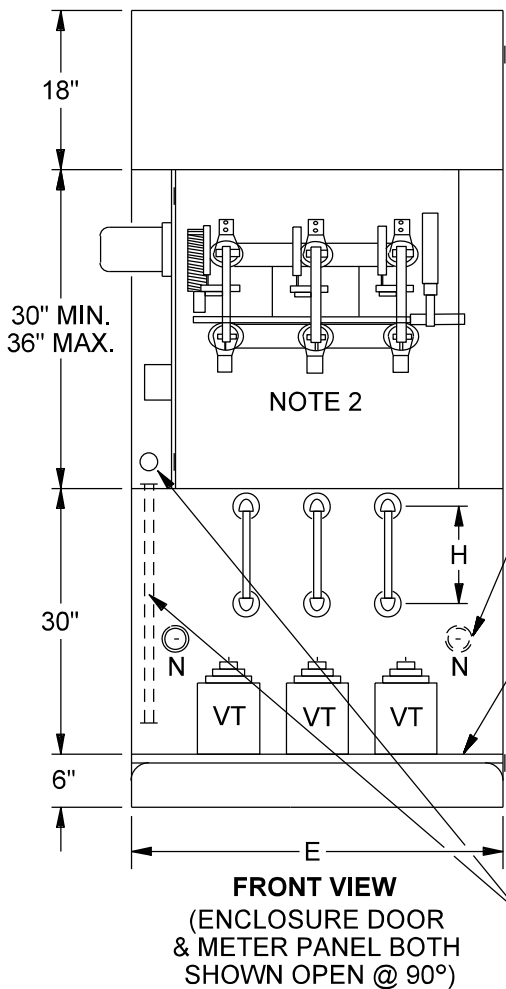
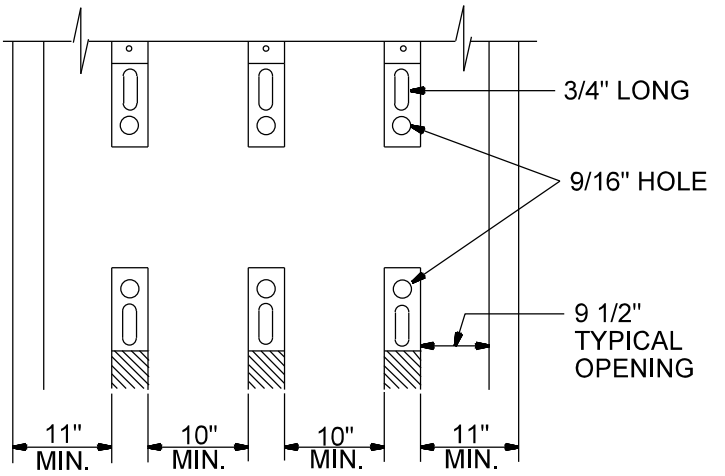
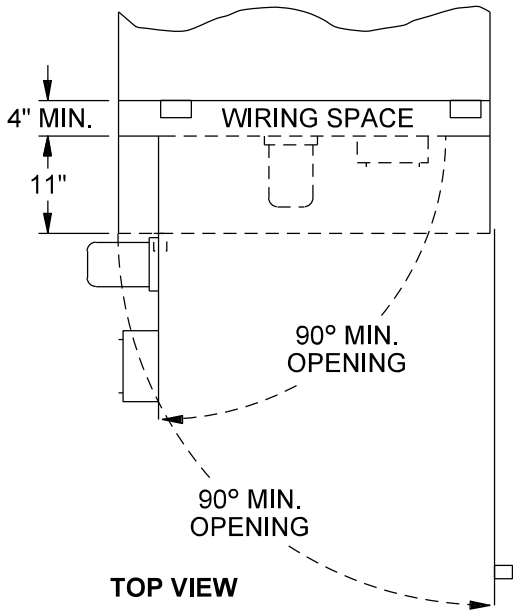

1" CONDUIT FOR VT AND CT SECONDARIES

1" VT & CT SECONDARY CONDUITS SHALL BE LOCATED ON THE SAME SIDE AS THE METER PANEL HINGES

CT COMPARTMENT

REFERENCE EUSERC DRAWING 401

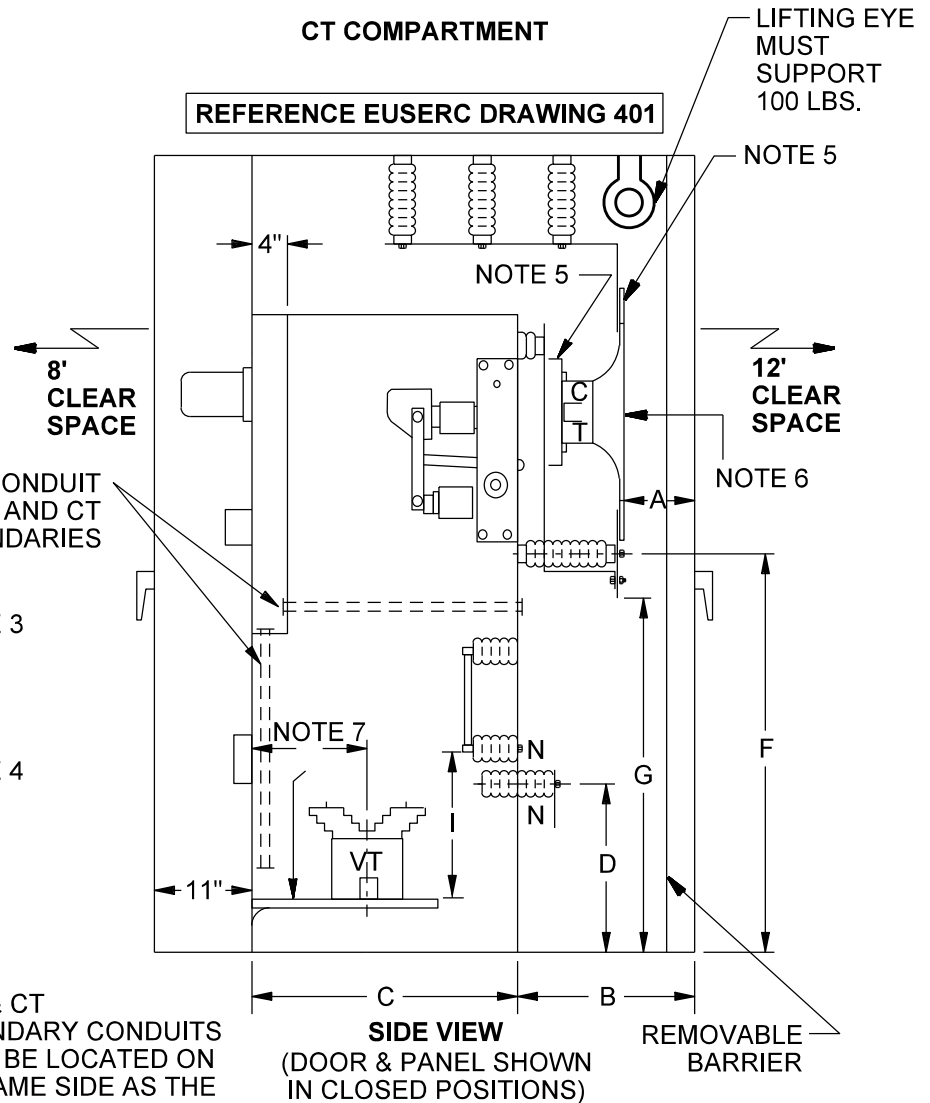

Electric Service Specifications
ESP
PROPRIETARY MATERIAL

REV: Title block update with Medium Voltage language		ISSUE DATE: 04/15/86
METERING & SES MEDIUM VOLTAGE METERING ENCLOSURE		REV. DATE: 12/10/25
		APPROVAL: J. Robbins
9-34-1		8509E98.DGN

Specifications	Voltage Rating		
	2,400	2,400/4,160 Y	7,200/12,470
Minimum Bare Bus Clearance Phase to Ground	3 1/2" min.	3 1/2" min.	6" min.
Minimum Bare Bus Clearance Phase to Phase	5" min.	5" min.	7 1/2" min.
Bare Bus to Insulated Barriers	2" min.	2" min.	2" min.
Dimension "A"	5" min. 10" max.	5" min. 10" max.	8" min. 10" max.
Dimension "B"	24" min.	24" min.	24" min.
Dimension "C"	24" min.	24" min.	24" min.
Dimension "D"	12" min.	12" min.	12" min.
Dimension "E"	36" min.	48" min.	48" min.
Dimension "F"	42" min. 48" max.	42" min. 48" max.	42" min. 48" max.
Dimension "G"	36" min.	36" min.	36" min.
Dimension "H" Fuse Mounting Clip Center	8 1/2" min.	8 1/2" min.	11 1/2" min.
Dimension Fuse Ferrule Diameter	1 5/8" min.	1 5/8" min.	1 5/8" min.
Dimension "I"	18" min.	18" min.	18" min.

NOTES:

1. PT compartment & voltage transformer disconnect panels shall be equipped with 2 lifting handles and attached with studs and wing nuts or may be side-hinged. Panels shall not exceed 9 square feet in area.
2. Isolation/ground switch requirements, refer to Note 8 in Section 9 – Medium Voltage Bus & Termination Requirements.
3. Insulated neutral termination, refer to Note 5 in Section 9 – Medium Voltage Bus & Termination Requirements.

<p>Electric Service Specifications</p>  <p>PROPRIETARY MATERIAL</p>	REV: Title block update with Medium Voltage language	
	<p>METERING & SES MEDIUM VOLTAGE METERING ENCLOSURE</p>	<p>ISSUE DATE: 04/15/86 REV. DATE: 12/10/25 APPROVAL: J. Robbins</p>
	9-34-2	ESS9-34-2.doc

4. Voltage Transformer Mounting Base, refer to Section 9 – Medium Voltage Instrument Transformer Mounting Pattern and Note 6 in Section 9 – Medium Voltage Bus & Termination Requirements.
5. Current Transformer Mounting Base, refer to Section 9 – Medium Voltage Instrument Transformer Mounting Pattern and Note 6 in Section 9 – Medium Voltage Bus & Termination Requirements.
6. Current Transformer Information, refer to Section 9 – Medium Voltage Indoor Current Transformer Dimensions (For Metering Purposes).
7. Voltage Transformer Clearance, refer to Section 9 – Medium Voltage Instrument Transformer Mounting Pattern.

<p>Electric Service Specifications</p>  <p>PROPRIETARY MATERIAL</p>	REV: Title block update with Medium Voltage language	ISSUE DATE: 04/15/86
	<p>METERING & SES MEDIUM VOLTAGE METERING ENCLOSURE</p>	<p>REV. DATE: 12/10/25 APPROVAL: J. Robbins</p>
9-34-3		ESS9-34-2.doc

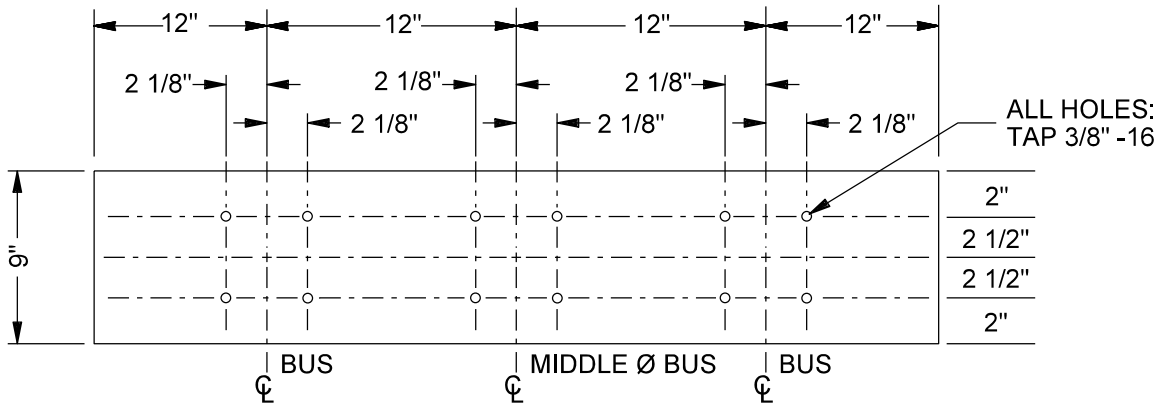

CURRENT TRANSFORMER MOUNTING BASE

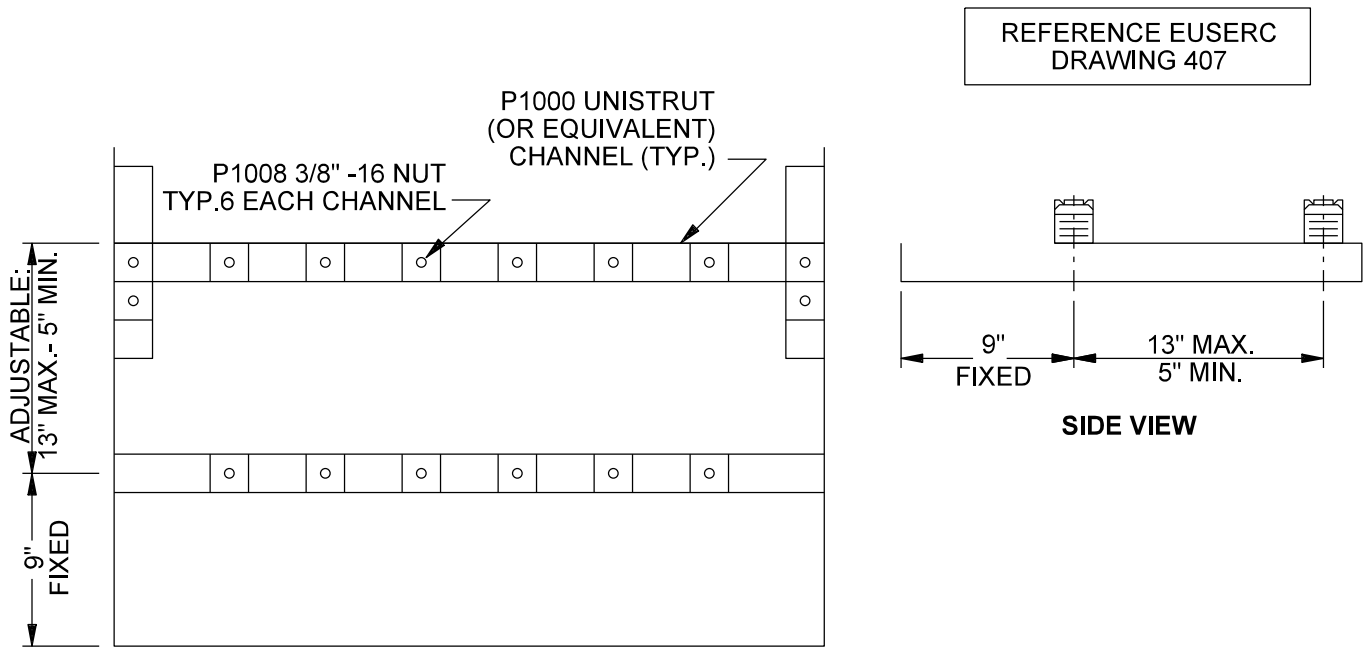

TOP VIEW OF CABINET (REF.)

VOLTAGE TRANSFORMER MOUNTING RAIL DETAIL

Reference EUSERC Drawing 407

<p>Electric Service Specifications</p>  <p>PROPRIETARY MATERIAL</p>	REV: Title block update with Medium Voltage language	
	<p>METERING & SES MEDIUM VOLTAGE INSTRUMENT TRANSFORMER MOUNTING PATTERN</p>	
	<p>ISSUE DATE: 01/15/94 REV. DATE: 12/10/25 APPROVAL: J. Robbins</p>	
	<p>9-35-1</p>	
		<p>8509E69.DGN</p>

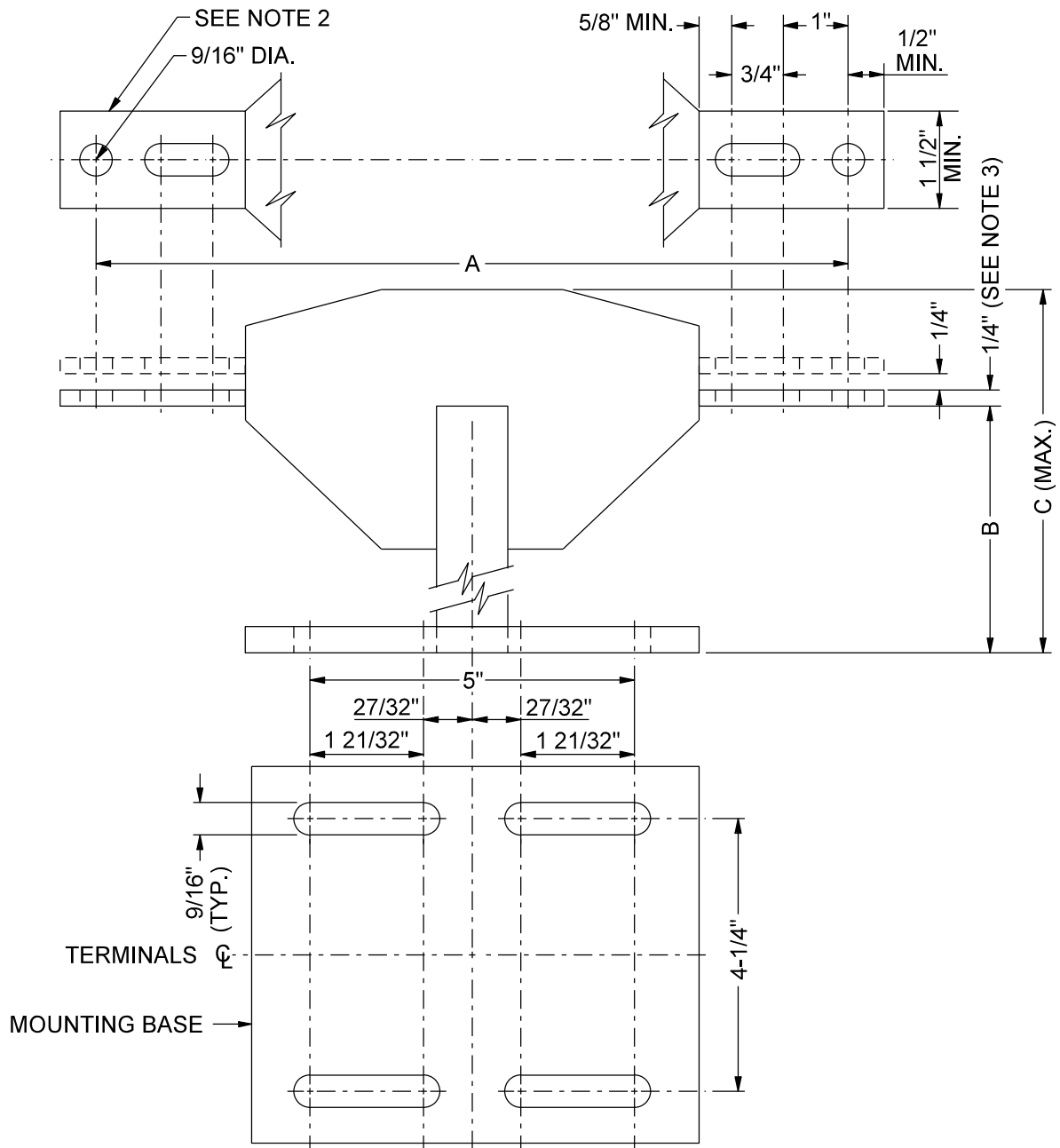

INSULATION CLASS	DIMENSIONS (SEE NOTES 2 & 4)		
	A	B	C (MAXIMUM)
5 kV	14"	5 3/4"	8"
15 kV	22"	9"	11 1/4"

NOTES (Reference EUSEPC Drawing 408)

1. Insulation classes are 5kV and 15kV. Basic Impulse Insulation Levels (BIL) for these classes are 60kV and 110kV, respectively.
2. Primary terminal rating is 10 to 156 amps.
3. 1/4" applies to multiple bar thickness. Single bar thickness may be from 3/16" to 3/8".
4. Unless otherwise indicated, tolerance is $\pm 1/16$ th of an inch.

<p>Electric Service Specifications</p>  <p>PROPRIETARY MATERIAL</p>	REV: Title block update with Medium Voltage language	
	<p>METERING & SES MEDIUM VOLTAGE INDOOR CURRENT TRANSFORMER DIMENSIONS (FOR METERING PURPOSES)</p>	
	9-36-1	<p>ISSUE DATE: 01/11/94 REV. DATE: 12/10/25 APPROVAL: J. Robbins 8509E109.DGN</p>

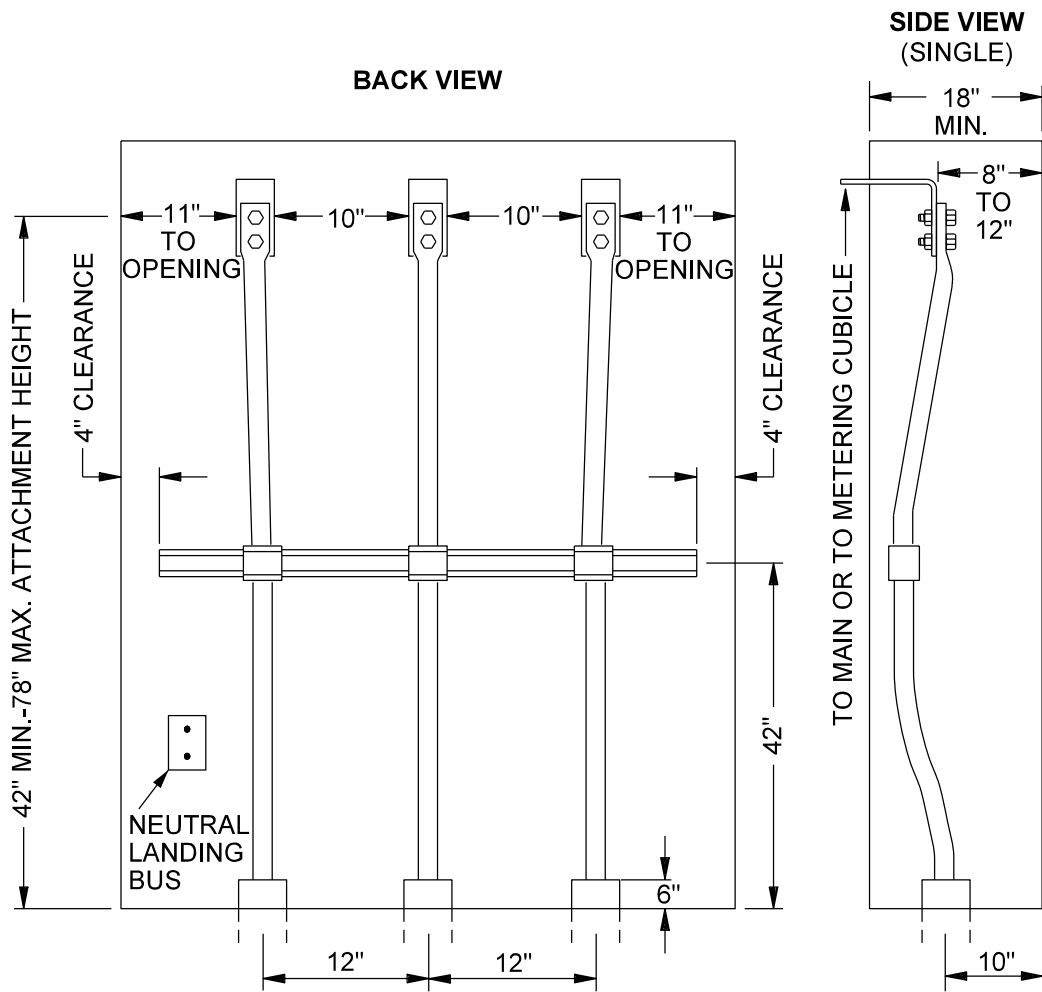

BASE PLAN

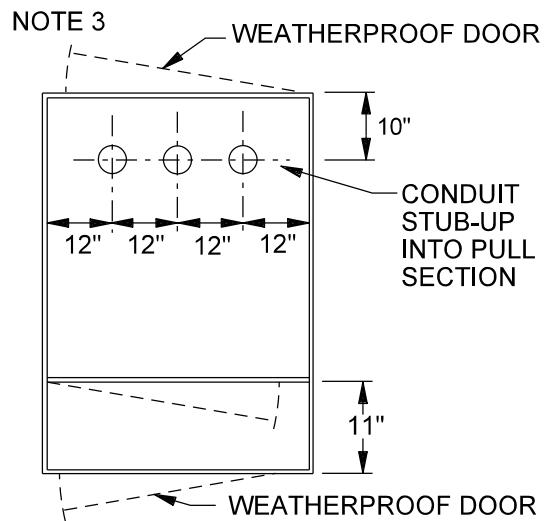

NOTES

1. 12" center-to-center distance between conduits, 10" front to back.
2. Phasing shall be A-B-C or C-B-A as determined by the Customer.
3. A 12' clearance is required in front of the pull section.

	REV: Title block update with Medium Voltage language	ISSUE DATE: 01/15/94
	METERING & SES MEDIUM VOLTAGE UNDERGROUND SERVICE TERMINATING PULL SECTION, 4-WIRE	REV. DATE: 12/10/25 APPROVAL: J. Robbins
9-37-1		8509E113.DGN

**DIE-CAST SOCKET
(60 A, 100 A)**

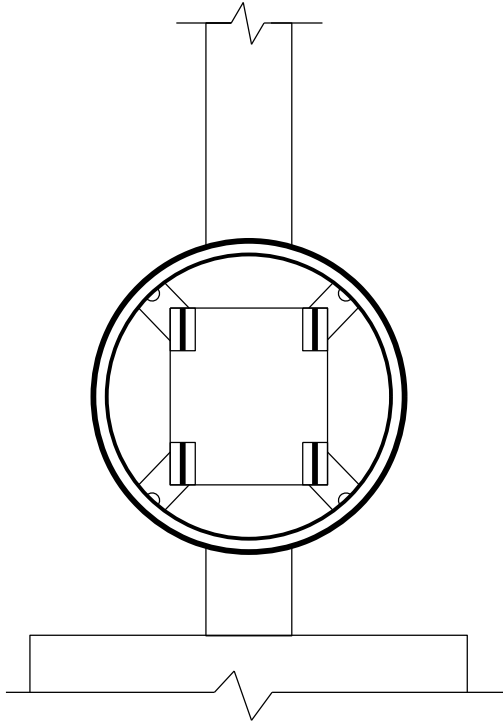

**SQUARE-BASE SOCKET
(100 A, 200 A)**

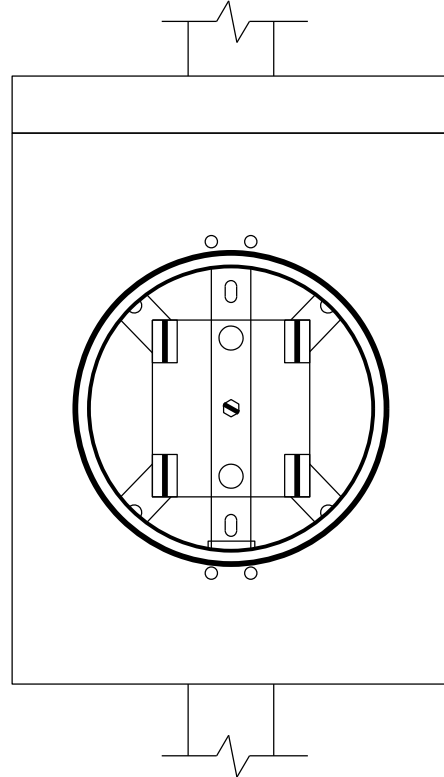

NOTES

1. Following a Customer's request for a service disconnect to allow work on their SES and prior to a service re-connect:
 - A. All round die-cast meter sockets must be replaced with an approved meter socket.

EXCEPTIONS

The meter socket is in good working order and:

- 60 A socket: The SES work is limited to replacement of a breaker in the existing load center, or
- 100 A socket: The SES work is limited to replacement of a breaker in the existing load center, or replacement of the load center with one having an equal rating.

- B. Square/rectangular meter sockets must be replaced with an all-in-one type.

EXCEPTIONS

The meter socket is in good working order and:

- The meter socket rating is not less than 100 A and
- The SES work is limited to replacement of a breaker in the existing load center, replacement of the load center with one having an equal rating, replacement of a rusted/damaged riser or mast, replacement of the mast conductors, or minor repairs such as replacement of meter clips.

2. The meter socket rating shall not be less than the minimum rating of the load center.

<p>Electric Service Specifications</p>  <p>PROPRIETARY MATERIAL</p>	<p>METERING & SES OVERHEAD / UNDERGROUND SERVICE DIE-CAST AND SQUARE BASE SOCKETS</p>	<p>ISSUE DATE: 11/27/18</p>
	<p>9-38-1</p>	<p>REV. DATE:</p> <p>APPROVAL: N. Sabbah</p> <p>8509E378.DGN</p>