

SECTION 5 CLEARANCES

<u>DESCRIPTION</u>	<u>PAGE</u>
Joint Trench.....	5-1
Joint Trench Feeder and Gas	5-2
Underground Conduit	5-3
Conduit Stub-Out to Residence, Joint Trench with Gas	5-4
Service Lateral Clearances.....	5-5
Swimming Pool, Overhead Line Clearances	5-6
Swimming Pool, Underground Line Clearances	5-7
Erosion Prevention Method, Enclosures Installed on Slopes.....	5-8
Dry Landscape, Controlled Area Detail.....	5-10
Customer Fencing, Equipment or Obstructions Adjacent to SRP Equipment Installations ...	5-11
Customer Fencing, Equipment or Obstructions Adjacent to SRP Steel Guard Post Installation	5-13
Clear Area for Customer Equipment Adjacent to Transformer	5-14
Service Entrance Section, Equipment Locations	5-15
Service Entrance Section Locations, Heights & Working Space Clearance	5-16
Vehicle Access Requirements, Switchgear & 1Ø Transformers	5-18
Vehicle Access Requirements, 3Ø Transformers	5-20
SRP Pad-Mounted Equipment, Pad Separation from a Building	5-22
Overhead/Underground Clearances, Above-Ground Storage Tanks Containing Volatile Flammable Liquids, NESC Rule 127	5-23
Underground Clearances, Fuel Storage Dispensing	5-24

<p>Electric Service Specifications</p>  <p>PROPRIETARY MATERIAL</p>	REV: UPDATED JOINT TRENCH NOTES & DRAWING	
	CLEARANCES	
	5-i	<p>ISSUE DATE: 11/09/12</p> <p>REV. DATE: 08/10/21</p> <p>APPROVAL: K. MacFadyen</p>
		ESS Index-5.doc

JOINT TRENCH

ALLOWED JOINT TRENCH INSTALLATIONS WITH SRP DISTRIBUTION

SRP Conductor Type	Utility			
	Telco and CATV	Natural Gas	Water and/or Sewer	SRP Communication
Services	Yes	Yes Residential Subdivisions only	No (See Note 1 & 2)	Yes
Service, Secondary and #2 Primary	Yes	Yes Residential Subdivisions only	No (See Note 2)	Yes
Service, Secondary, #2 and 4/0 Primary	Yes	Yes Commercial Private Property Only (not in PUE)	No (See Note 2)	Yes
Feeder	Yes	No (See Note 6)	No (See Note 2)	Yes

NOTES

1. In single family residential subdivisions, water service is permitted in a joint trench with SRP service conduit from the PUE service entrance section working space. Water lines shall maintain minimum 12" separation (radial) from the SRP service conduit.
2. Water and/or sewer is not permitted in a joint trench with SRP electric facilities, unless trenching is in solid rock and supplemental protection is provided for the SRP facility, minimum 2500 Psi concrete no loads (weight) above or between facilities.
3. SRP Electric and SRP Communications facilities shall be at the bottom of the trench.
4. All joint trench locations shall have a maximum backfill soil density per ASTM D698, at or near optimum moisture (see pages 6-19 through 6-20). Mechanical compaction is not allowed within 6" of electric conduit.
5. Joint trench width shall not exceed 30".
6. Joint use trench with feeder is not allowed because it presents an obstacle to future feeder access. The following acceptable alternatives will be allowed:
 - A. A separate feeder and gas trench with a minimum of 2' of undisturbed earth between the two trenches.
 - B. A shelf-type trench with a minimum horizontal clearance of 6' and a minimum vertical clearance of 12" between the feeder and gas.

Electric Service Specifications  PROPRIETARY MATERIAL	REV: UPDATED NOTE 6	ISSUE DATE: 05/07/03
	CLEARANCES JOINT TRENCH	REV. DATE: 08/10/21
	5-1	APPROVAL: K. MacFadyen
		ESS5-01.doc

SEPARATE TRENCH

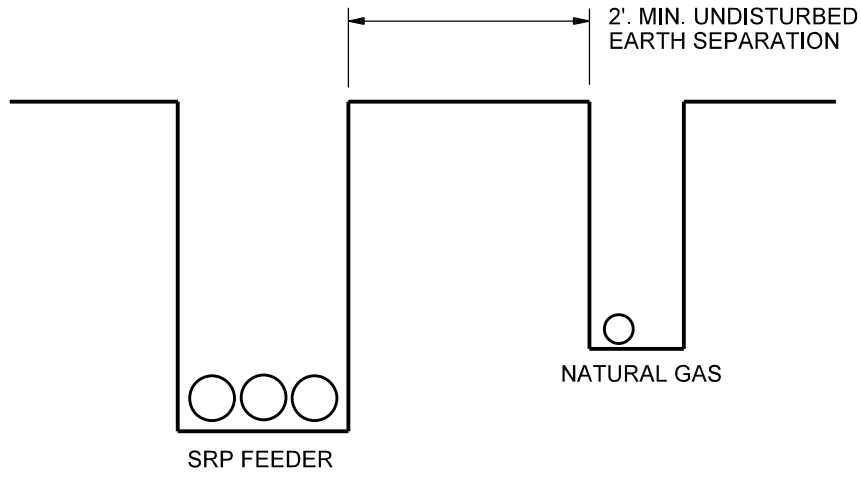

JOINT TRENCH FEEDER WITH GAS

(SHELF OR STEP-TYPE TRENCH)

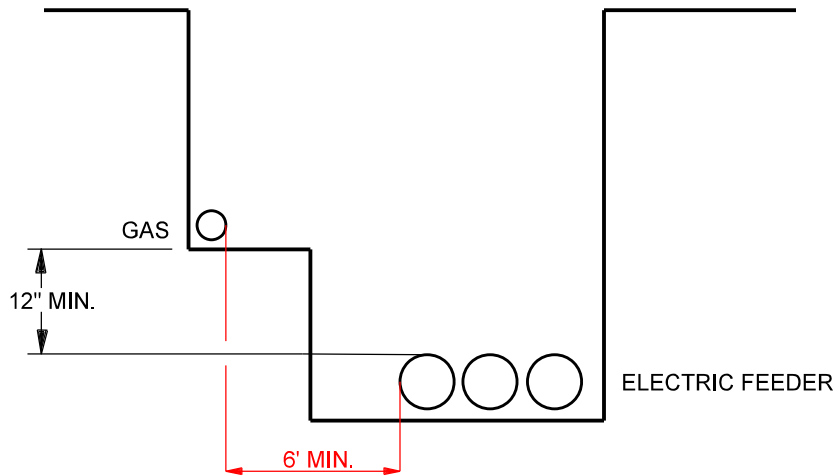

NOTE: See Page 5-1, NOTE 2A and 2B.

<p>Electric Service Specifications</p>  <p>PROPRIETARY MATERIAL</p>	<p>REV: UPDATED JOINT TRENCH DRAWING</p>	
	<p>CLEARANCES JOINT TRENCH FEEDER & GAS</p>	<p>ISSUE DATE: 11/12/10 REV. DATE: 08/10/21 APPROVAL: K. MacFadyen</p>
<p>5-2</p>		<p>8509E317.DGN</p>

NOTES

1. Minimum vertical or horizontal separations between electric conduit systems and communications conduit systems (NESC Rule 320B2):

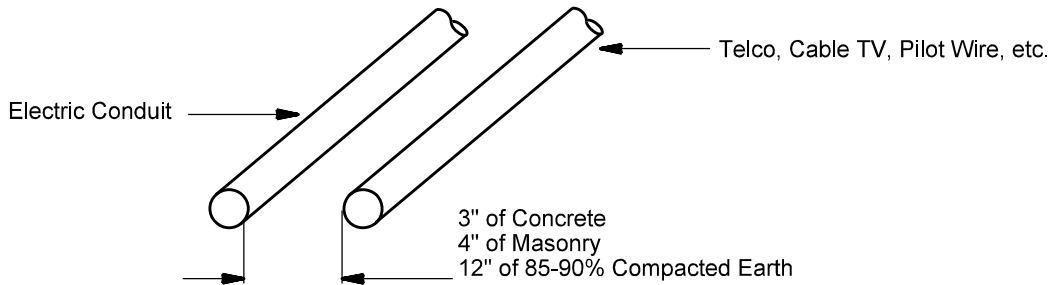

2. Minimum clearance between an electric conduit system and other existing underground structures or utilities (Note 4):

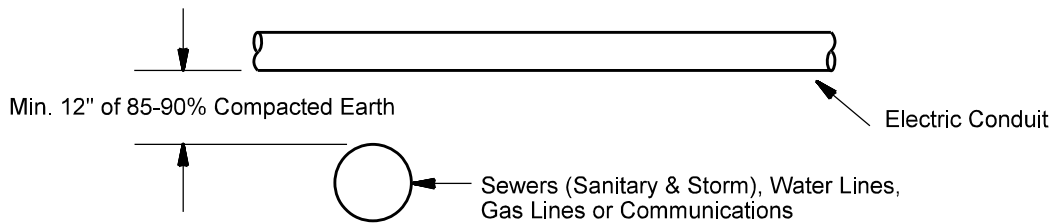

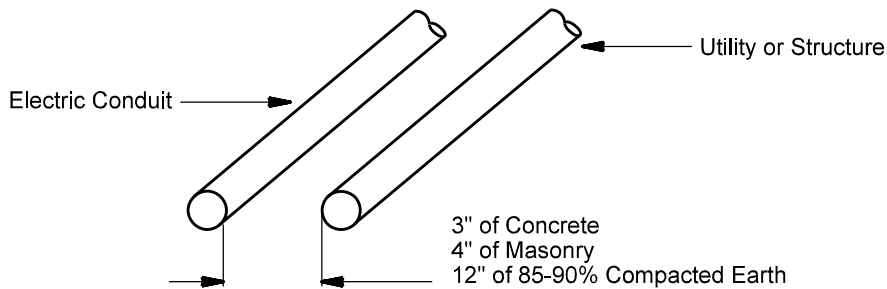

3. Horizontal clearance for parallel structures (NESC Rule 320B):

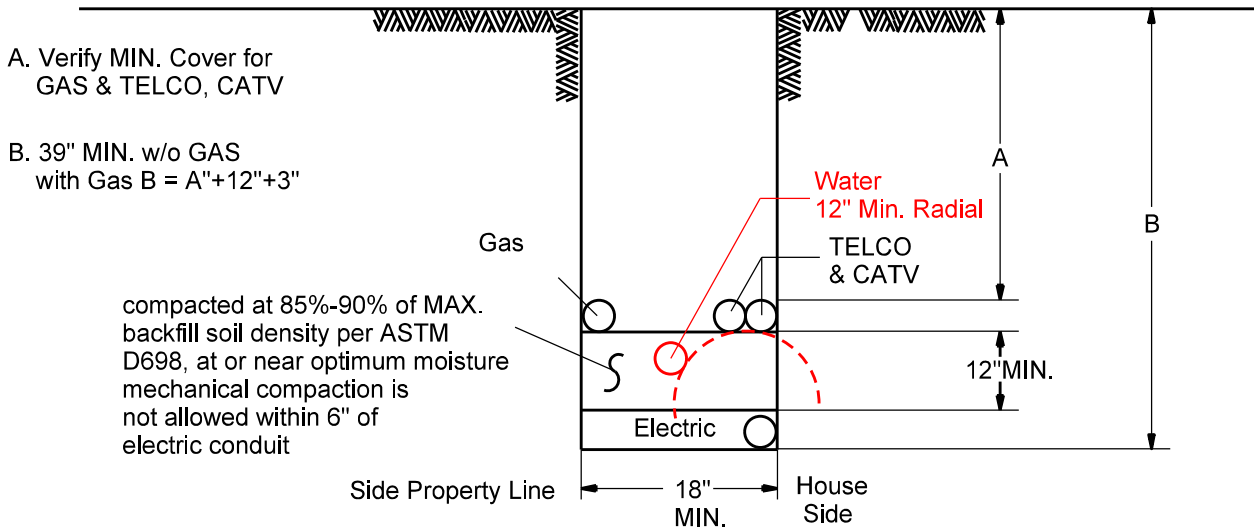
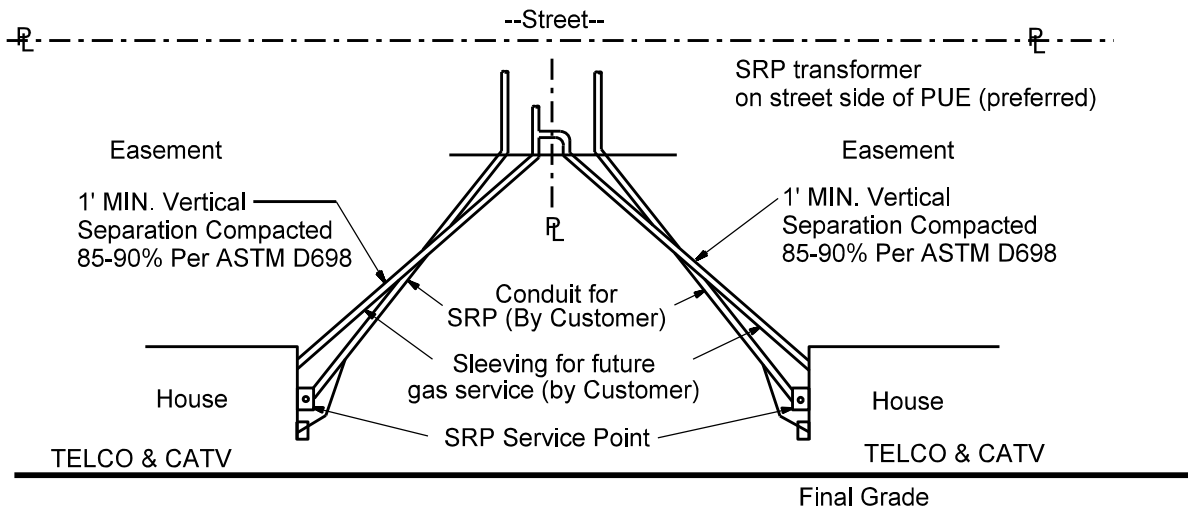
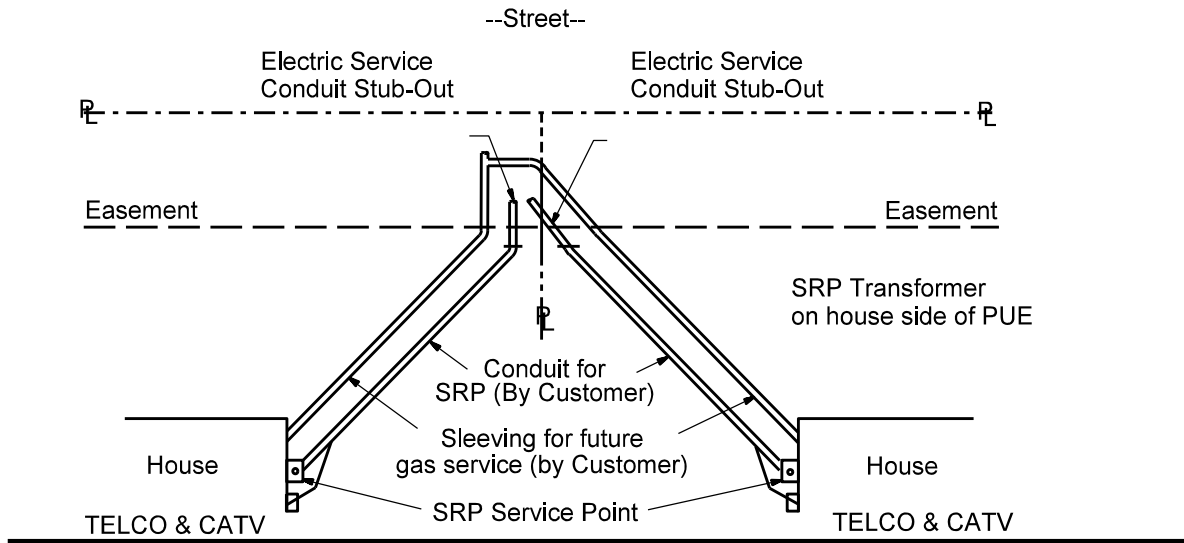

4. An alternative to 12" of 85-90% compacted earth is a rigid support for the upper structure to prevent it from transferring any direct load to lower structure.
5. Conduit should be installed as far as practical from a water main to protect it from being undermined if the main breaks.
6. Municipals and other utilities may have additional requirements.

<p>Electric Service Specifications</p>  <p>PROPRIETARY MATERIAL</p>	<p>CLEARANCES</p> <p>UNDERGROUND CONDUIT</p>	<p>ISSUE DATE: 04/15/86</p>
	<p>5-3</p>	<p>REV. DATE: 10/25/12</p> <p>APPROVAL: W.LARAMIE</p> <p>8509E149.DGN</p>



<p>Electric Service Specifications</p>  <p>PROPRIETARY MATERIAL</p>	<p>REV. ADDED WATER LOCATION</p>	<p>ISSUE DATE: 02/11/05</p>
	<p>CLEARANCES CONDUIT STUB-OUT TO RESIDENCE JOINT TRENCH</p>	<p>REV. DATE: 04/21/20</p>
	<p>5-4</p>	<p>APPROVAL: J. Luera</p>
		<p>8509E160.DGN</p>

CLEARANCE OF SERVICE DROPS

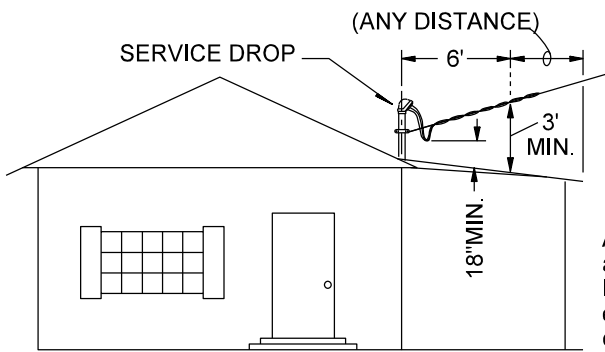

ROOF NOT READILY ACCESSIBLE

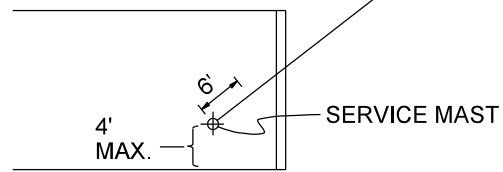

TOP VIEW

Applicable for triplex cable and a thru-the-roof mast only. Roof is not readily accessible to pedestrians (no doorway, ramp, stairway or permanently mounted ladder). The mast is located a maximum horizontal distance of 4' from roof edge. The minimum clearance of the cable above the roof within a 6' radius of the mast may be 18". Beyond the 6' radius, the minimum clearance of the cable above the roof may be 3'.

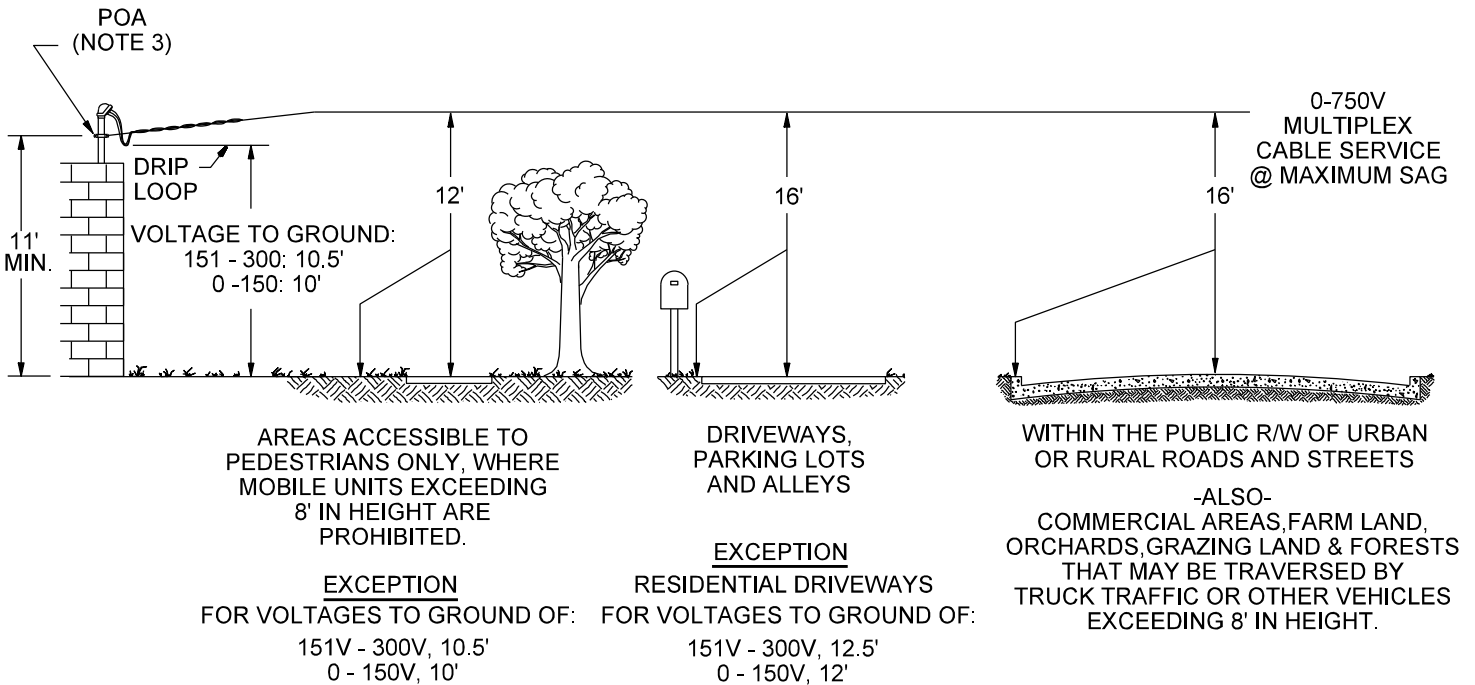

NOTES

1. Clearance from building openings (NESC Art. 234 c): Conductors shall have a minimum horizontal clearance of 5' from windows, doors, porches, fire escapes or similar locations.
2. Clearance from SRP overhead poles and lines: Customer's overhead POA shall not be placed within 10' of any SRP pole and must not be located within 10' of SRP's line.
3. POA shall be 11' minimum above ground but electrical clearances may require the POA to be higher. Contact SRP Design representative to determine actual required POA height.
4. Upper drawing: NESC Rule 234C3; lower drawing: NESC Rule 232.
5. The AHJ may have more stringent requirements for facilities under their jurisdiction.

	<p>CLEARANCES SERVICE LATERAL CLEARANCES</p>	<p>ISSUE DATE: 04/15/86</p>
	<p>5-5</p>	<p>REV. DATE: 01/27/14</p> <p>APPROVAL: W.LARAMIE</p> <p>8509E108.DGN</p>

SWIMMING POOL CLEARANCES FROM UTILITY OWNED, OPERATED AND MAINTAINED SUPPLY LINES AND SERVICE DROPS (NESC Rule 234E)

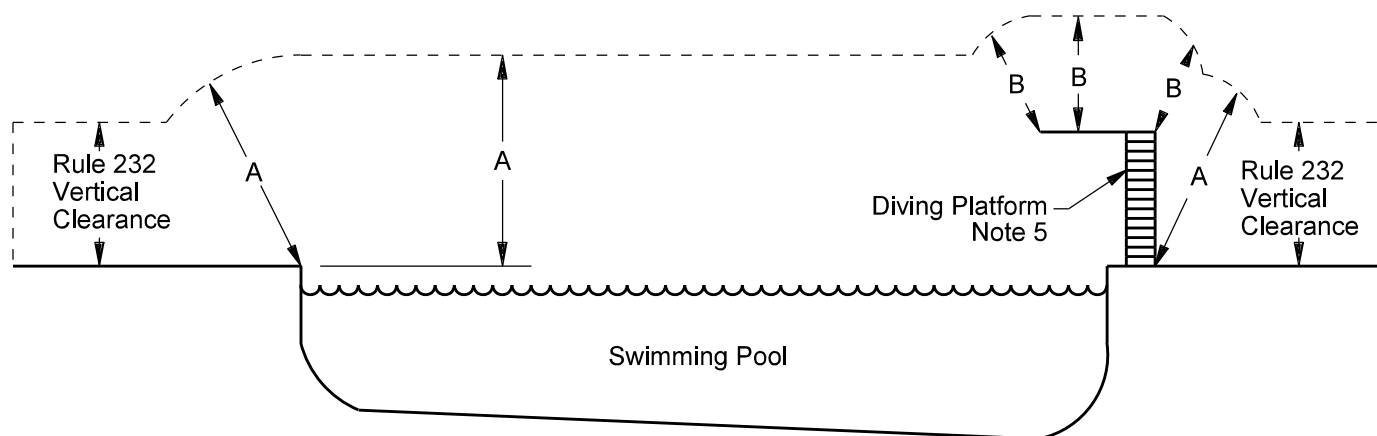

Clearance Dimensions (Feet)

DIMENSION	GROUNDING GUYS & NEUTRALS 0-22 kV UNGROUNDING GUYS EXPOSED TO 0-300 V	MPX CABLE 0-750 V UNGROUNDING GUYS EXPOSED TO 300-750 V	OPEN WIRE 0-750 V	UNDERGROUNDING GUYS EXPOSED TO 750 V-22 kV	OPEN WIRE 750 V-22 kV	69 kV
"A"	22 Note 2	22.5 Note 2	23	24.5	25	26
"B"	14 Note 2	14.5 Note 2	15	16.5	17	18

NOTES

- All voltages are phase to ground, except 69 kv, which is phase to phase with conductor at maximum operating temperature of 212°F for distribution and 167°C for transmission, final sag.
- Does not apply when conductors are more than 10' horizontally from edge of pool or diving platform.
- Minimum clearances must be maintained from neighboring services.
- Avoid crossing over pools whenever possible.
- To determine the minimum clearance over a diving platform, use the larger of:
 - Dimension "A" from table
 - Dimension "B" plus the diving platform height
- To calculate the vertical clearance with a given "A" or "B" dimension and a horizontal distance from an edge:

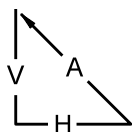

$$V = \sqrt{A^2 - H^2}$$

- Contact local municipality for additional clearance requirements which may prevail.

Electric Service Specifications PROPRIETARY MATERIAL	REV. UPDATED TABLE AND REFORMATTED	
	CLEARANCES SWIMMING POOL OVERHEAD LINE CLEARANCES	ISSUE DATE: 04/15/86 REV. DATE: 06/28/18 APPROVAL: N.SABBAH
	5-6	8509E82.DGN

Rear Lot Easement Where Facilities Exist

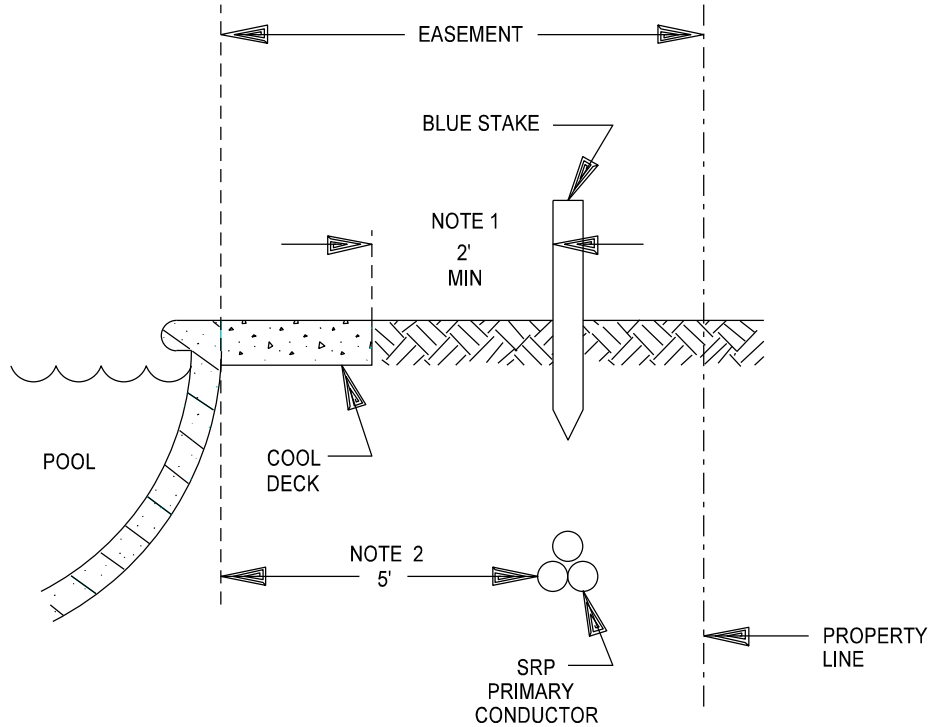

NOTES

1. Cool decking may encroach to within 2' of the staked location of SRP underground facilities.
2. The swimming pool and auxiliary equipment, above or below grade, shall not be installed within 5' of direct buried cable. If facilities are in conduit, a separation of 2' is required.
3. Contact Land Rights Management to request permission to encroach on an SRP easement or log onto [srpnet.com/about/land/secure/Land Department/EasementEncroachment.aspx](http://srpnet.com/about/land/secure/Land%20Department/EasementEncroachment.aspx) to access the online form.

<p>Electric Service Specifications</p>  <p>PROPRIETARY MATERIAL</p>	<p>CLEARANCES SWIMMING POOL UNDERGROUND LINE CLEARANCES</p>	<p>ISSUE DATE: 09/30/90</p>
	<p>5-7</p>	<p>REV. DATE: 10/25/12</p> <p>APPROVAL: W.LARAMIE</p>

FRONT WALL

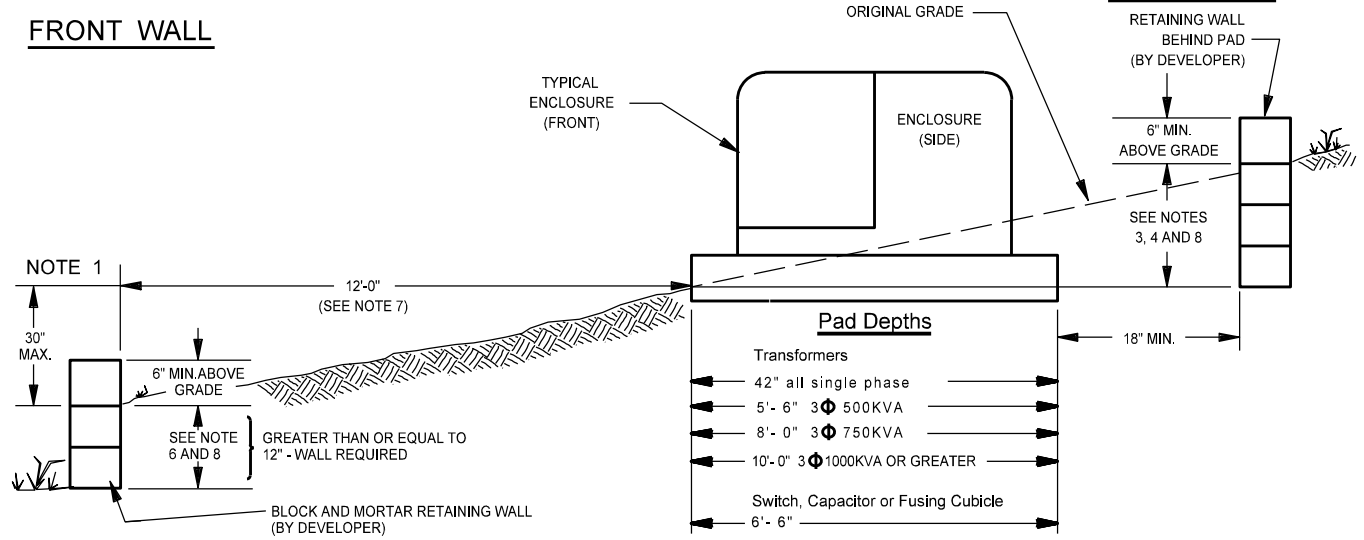

SIDE WALL

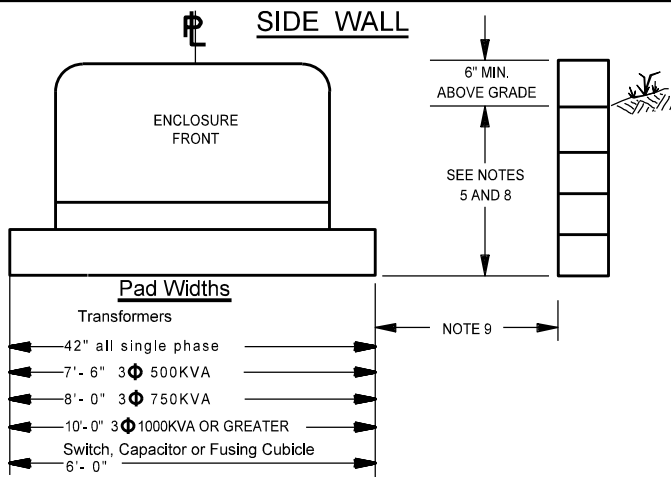

PLAN VIEW OF WALLS

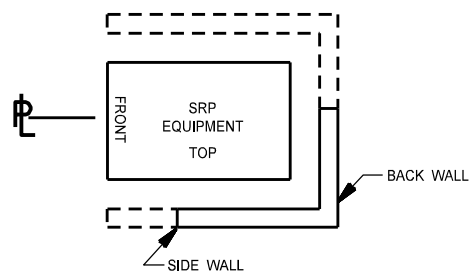

NOTES

1. When it becomes necessary to notch-out or fill a slope to install an enclosure, the cleared area should be of sufficient size to accommodate the enclosure and shorings. Slope in front of enclosure shall not be greater than 30" in 12'. All grading is to be done by developer.
2. Area under and behind pad must be level and compacted. See compaction requirements on page 6-20.
3. A back retaining wall is required when the change in ground elevation is 12" or more at any point, 18" or less behind the pad.
4. A side retaining wall is required when the change in ground elevation is 18" or more at any point, 18" or less behind the pad.
5. A side retaining wall is required when the change in ground elevation is 12" or more at any point, 18" or less to the side of the pad.
6. A front retaining wall is required when the change in ground elevation is 12" or more at any point, 12' or less in front of the pad.
7. This dimension may be 4' if measured from curb. Slope in front of enclosure shall not be greater than 10" in 4'.
8. Developer shall install guardrail per the AHJ.
9. 3' minimum on all equipment EXCEPT 1Ø transformers. On 1Ø transformers, 18" minimum allowed for fire and retention walls.
10. See Dry Landscape Requirements on page 5-8.

<p>Electric Service Specifications</p>  <p>PROPRIETARY MATERIAL</p>	PAGE 1 OF 2	
	<p>CLEARANCES EROSION PREVENTION METHOD ENCLOSURES INSTALLED ON SLOPES</p>	
	5-8	<p>ISSUE DATE: 04/15/86 REV. DATE: 11/13/12 APPROVAL: W.LARAMIE</p>
		8509E107.DGN

SIDE VIEW

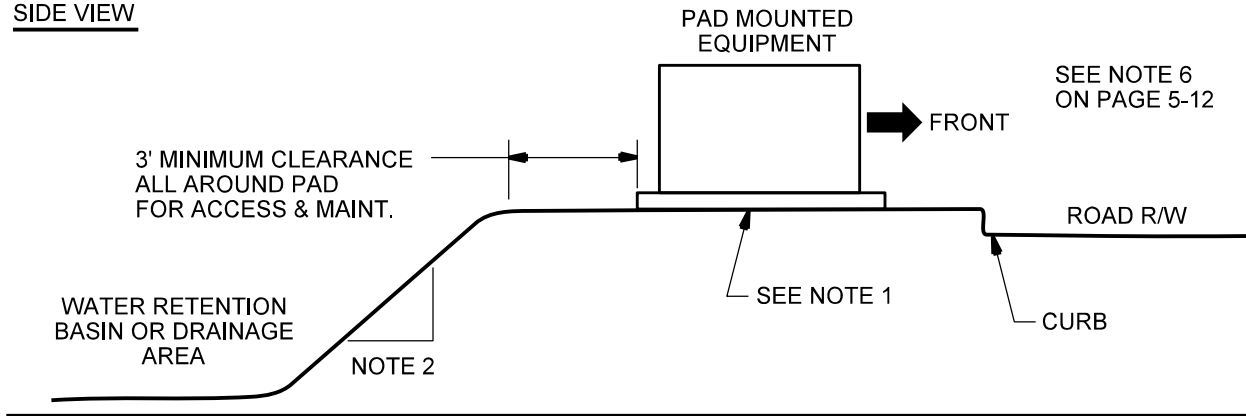

BACK VIEW

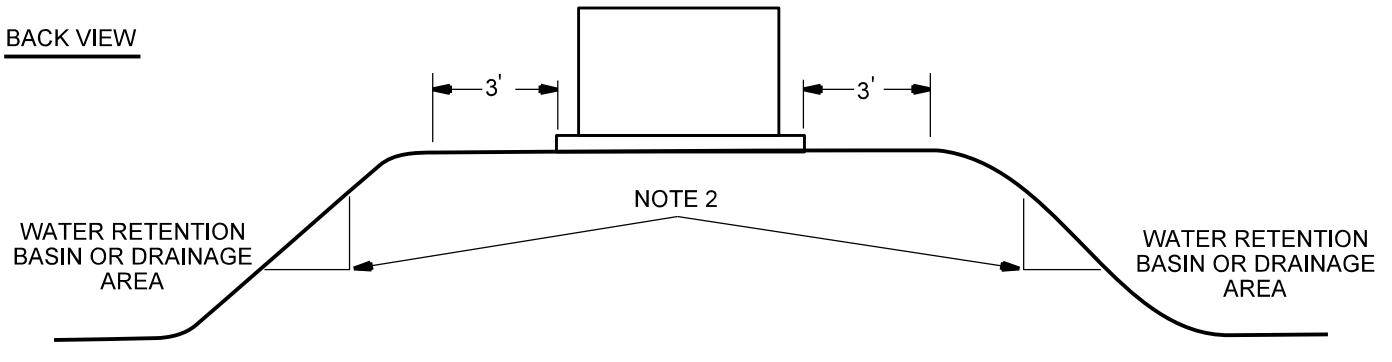

PLAN VIEW

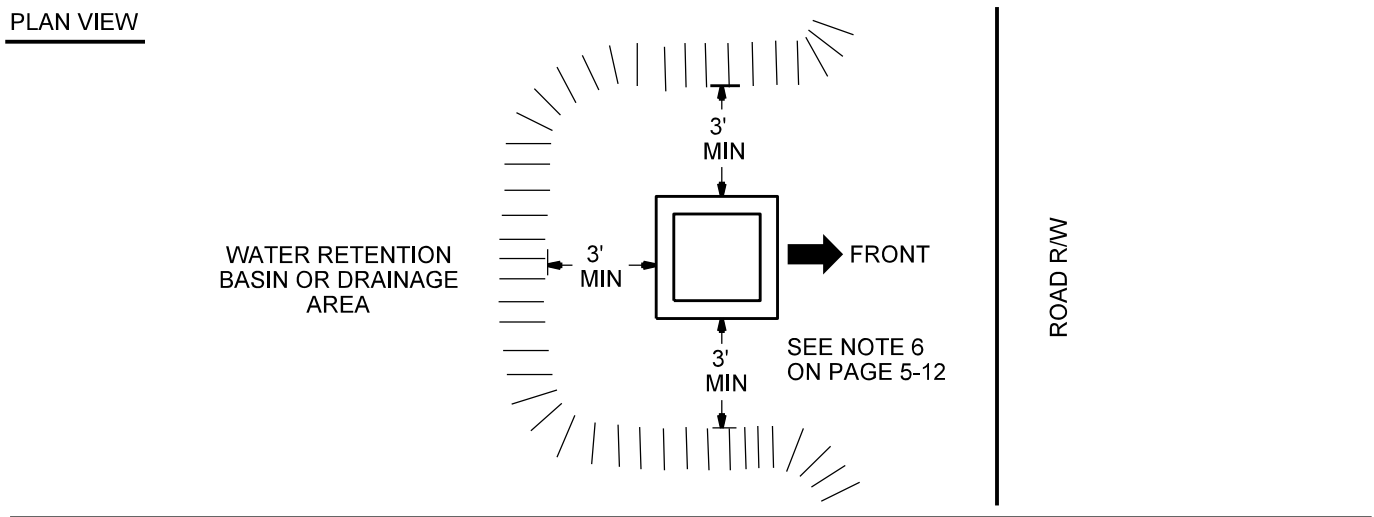

NOTES

1. The customer shall provide SRP a geotechnical report of the area confirming compliance with SRP's compaction requirements. All fill material shall be native compacted fill and in compliance with the geotechnical report. See top of page 6-20.
2. The maximum slope per SRP requirements is 3 horizontal to 1 vertical. If steeper, submit a set of engineered calculations showing a slope stability analysis or a retaining wall design to Policy, Procedures & Standards for approval.

<p>Electric Service Specifications</p>  <p>PROPRIETARY MATERIAL</p>	PAGE 2 OF 2		
	<p>CLEARANCES EROSION PREVENTION METHOD ENCLOSURES INSTALLED ON SLOPES</p>		<p>ISSUE DATE: 04/15/86</p> <p>REV. DATE: 11/13/12</p> <p>APPROVAL: W.LARAMIE</p>
	5-9		8509E135.DGN

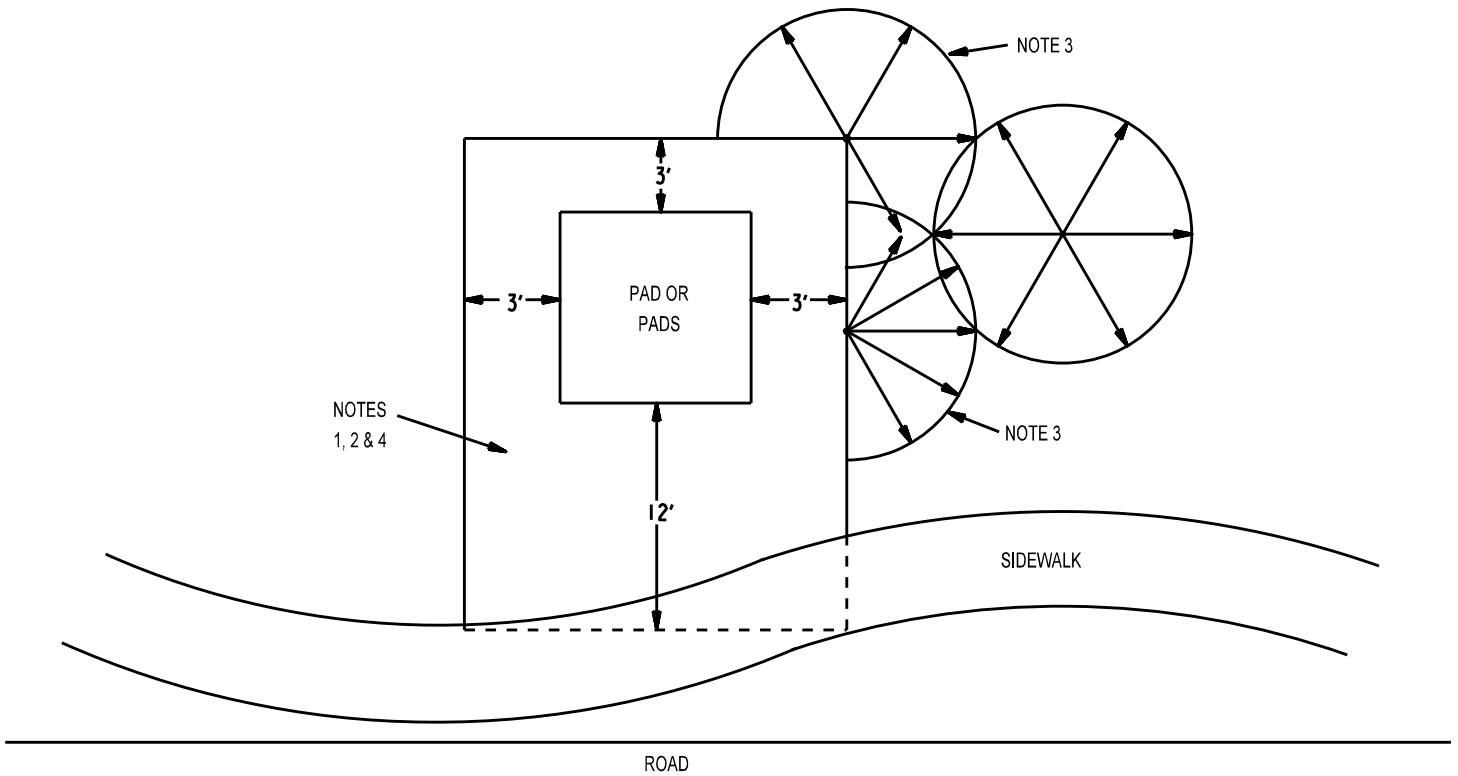

NOTES

1. Easement grantor shall maintain a clear area that extends 3' from and around all edges of all transformer pads and other equipment pads and a clear operational area that extends 12' immediately in front of all transformer and other equipment openings. Do not place obstructions, trees, shrubs, fixtures or permanent structures within aforementioned areas. Easement documents may supersede these requirements.
2. This same clear area shall be dry landscaped.
3. Direct sprinkler heads away from pad-mounted equipment, as shown above. Sprinkler heads shall not spray on pad-mounted equipment or dry landscaped area around equipment.
4. Dry landscape surface may be native soil, concrete, asphalt pavement or crushed granite or gravel with a maximum particle size no greater than 1".
5. A border curb is required if SRP installs the landscape.

<p>Electric Service Specifications</p>  <p>PROPRIETARY MATERIAL</p>	<p>CLEARANCES DRY LANDSCAPE CONTROLLED AREA DETAIL</p>	<p>ISSUE DATE: 03/02/01</p>
	<p>5-10</p>	<p>REV. DATE: 10/25/12</p> <p>APPROVAL: W.LARAMIE</p> <p>8509E133.DGN</p>

DETAIL 1

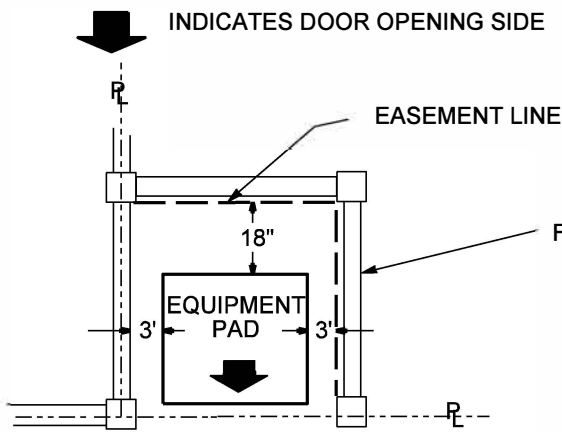

- ALLEY -
PAD MOUNTED TRANSFORMER
OR OTHER EQUIPMENT IN ALLEY

DETAIL 2

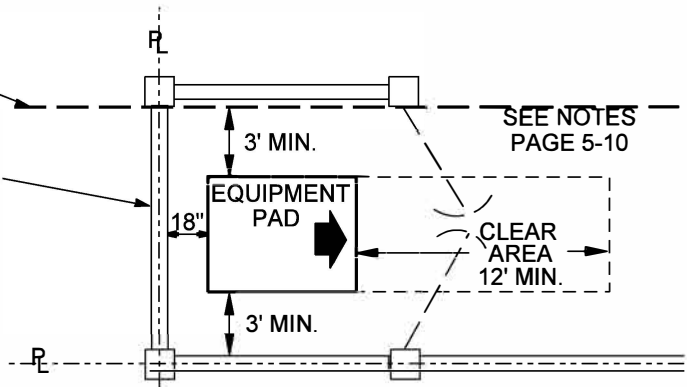

PAD MOUNTED TRANSFORMER OR OTHER
EQUIPMENT IN BACK LOT UTILITY EASEMENT

DETAIL 3

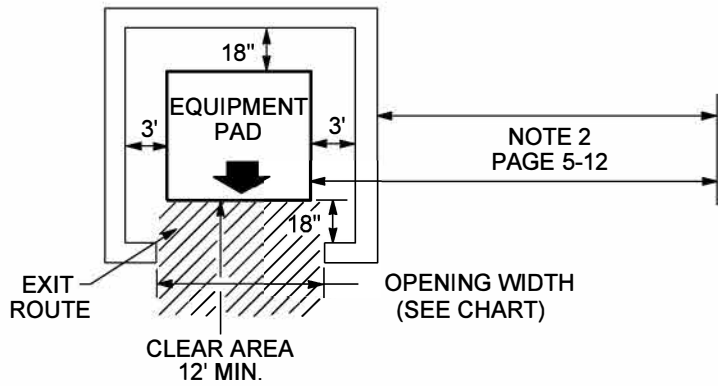

EQUIPMENT ENCLOSERS
IN COMMERCIAL AREAS

DETAIL 4

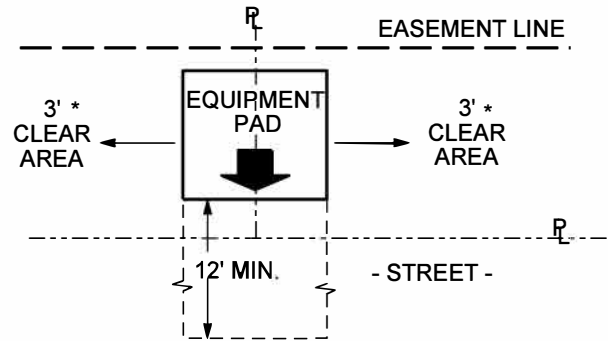

PAD MOUNTED TRANSFORMER OR OTHER
EQUIPMENT IN FRONT OR SIDE LOT EASEMENT
* MAY BE 18" FOR FIRE OR RETENTION WALLS
AROUND TRANSFORMERS ONLY.

NOTES

The distances shown around equipment pads shall be totally unobstructed. These distances also apply to poles & structures in overhead areas.

EXCEPTION: No pole or structure shall be totally enclosed by a wall or fence with an access gate (upper right diagram not allowed in overhead areas).

TYPE OF EQUIPMENT	MINIMUM OPENING WIDTH
All Except 3Ø Transformers Below	6 1/2'
150 - 500 kVA Transformers	10'
750 - 1,000 kVA Transformers	12'
1,500 - 2,500 kVA Transformers	12'

CUSTOMER FENCING, EQUIPMENT OR OBSTRUCTION ADJACENT TO SRP EQUIPMENT INSTALLATIONS

NOTES

1. Do not build fence, gateposts or support structures inside easement lines (except on property lines in back lot easements).
2. No building addition, building overhang or structure shall be built closer than the minimum limits shown on page 5-22 from the edge of any equipment pad, unless approved in writing by SRP.
3. There shall be no roof or covering over any pad-mounted equipment.
4. A gate, the full width of the opening (per the table on the previous page), is permissible across the front of equipment. The gate may be of solid material if a 6" clearance for ventilation is maintained between bottom of gate and ground level. The gate is allowed to be lower than 6" if constructed of mesh, bar, louver or similar ventilating material. Gate must be open at least 90° for full opening width access and must be free of locks that would inhibit access by utility personnel. Customer must furnish any gate.
5. If a solid gate is installed on an enclosure around a transformer, then ventilation openings shall be provided on two opposite sides (space under the gate may count as one of them). The openings shall be located near the bottom of the enclosure with the following minimum area for airflow.

Transformer Rating Vent Opening (each side)	
2,000 and 2,500 kVA	625 sq. inches
1,000 and 1,500 kVA	375 sq. inches
500 and 750 kVA	190 sq. inches
225 and 300 kVA	80 sq. inches
Up to 150 kVA	40 sq. inches

6. No obstruction, including but not limited to, fences, trees, shrubs or other similar large vegetation and large rocks, shall be permitted within 12' of the opening side of equipment. The sides of all transformers and equipment require at least 3' of clearance from the edge of the pad to any obstruction (EXCEPTION: Page 5-11, Detail 4) and 18" from the back. For front or side lot easements the easement line defines the clearance to the back of pad-mounted equipment.
7. When gates are in the maximum open position, the exit path shall be a minimum 24" wide perpendicular to the opening and a minimum of 6' from the equipment pad. The exit path shall be directly away from the opening side of the pad-mounted equipment.
8. Maintain a level dry area 3' around, and 12' in front of all pad-mounted equipment (see page 5-10).
9. See page 5-14 for clearances to non-SRP equipment

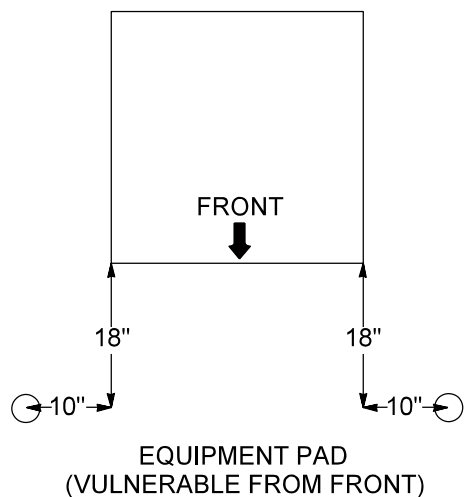
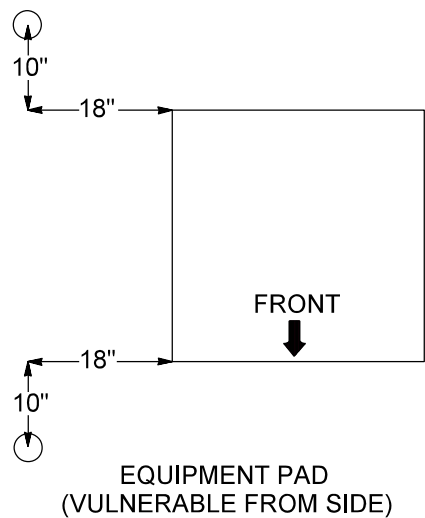
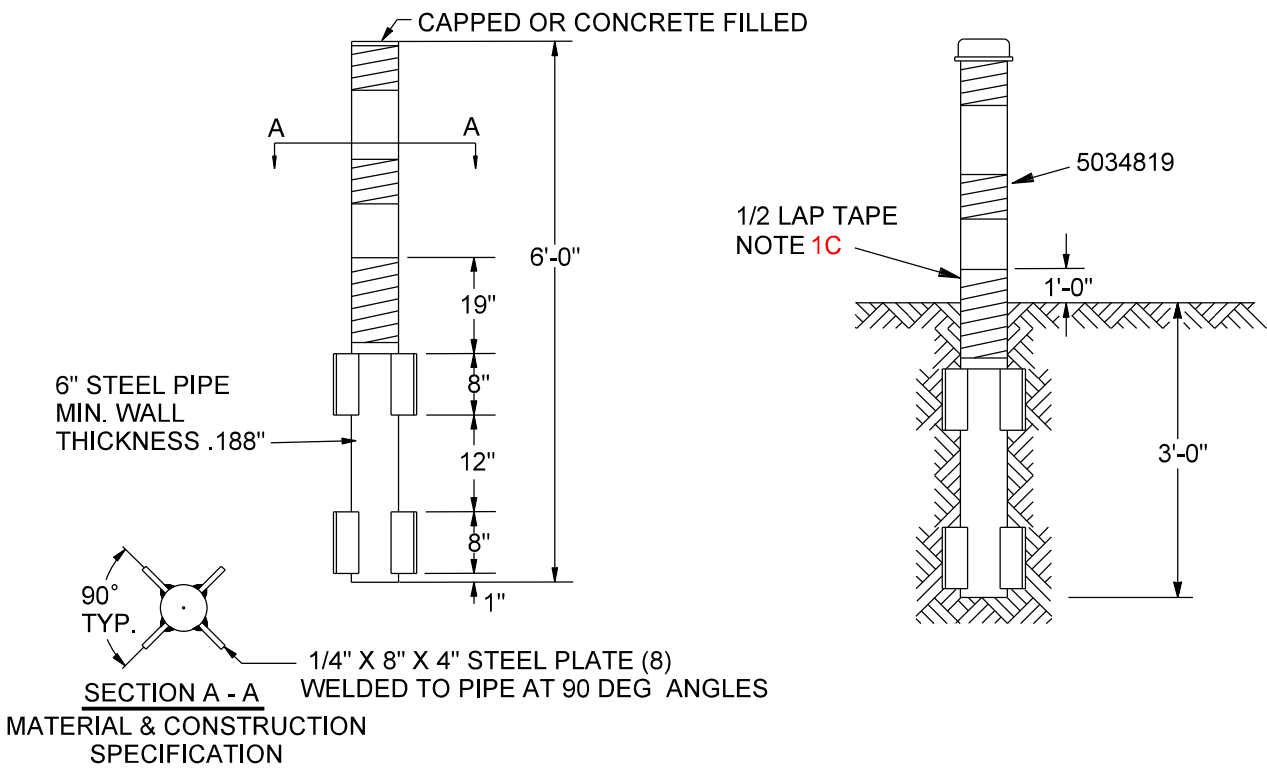

- STEEL GUARD POST INSTALLATION
- NOTES**
1. Material & Construction Specification
 - A. Surface to be coated will receive a commercial sandblast cleaning pretreatment immediately prior to coating.
 - B. Paint, zinc metal spray of 5.0 mils., or hot dip galvanize are acceptable coatings.
 - C. The buried portion of the guard post shall be wrapped with 2" x 10 mil. thick plastic tape overlapped a minimum half the tape width as shown above. (Not required when backfilled with concrete).
 2. Installation (See page 11-23 for approved suppliers.)
 - A. Guard post to be installed where necessary to protect pad-mounted equipment. Do not install guard post in an area that would restrict access to the equipment. Protect each side exposed to vehicular access.
 - B. Backfill with concrete (Material Item #: 5075323) or backfill with native soil and compact to 95% density.
 - C. Guard posts shall allow for unrestricted operation of doors.
 - D. Apply reflective tape (Material Item #: 5010577) 18" and 30" above the ground line.

Electric Service Specifications  PROPRIETARY MATERIAL	REV. ADDED NOTES	PAGE 3 OF 3
	CLEARANCES CUSTOMER FENCING, EQUIPMENT OR OBSTRUCTIONS ADJACENT TO SRP STEEL GUARD POST INSTALLATION	
	5-13	ISSUE DATE: 04/15/86 REV. DATE: 11/06/17 APPROVAL: N.SABBAH

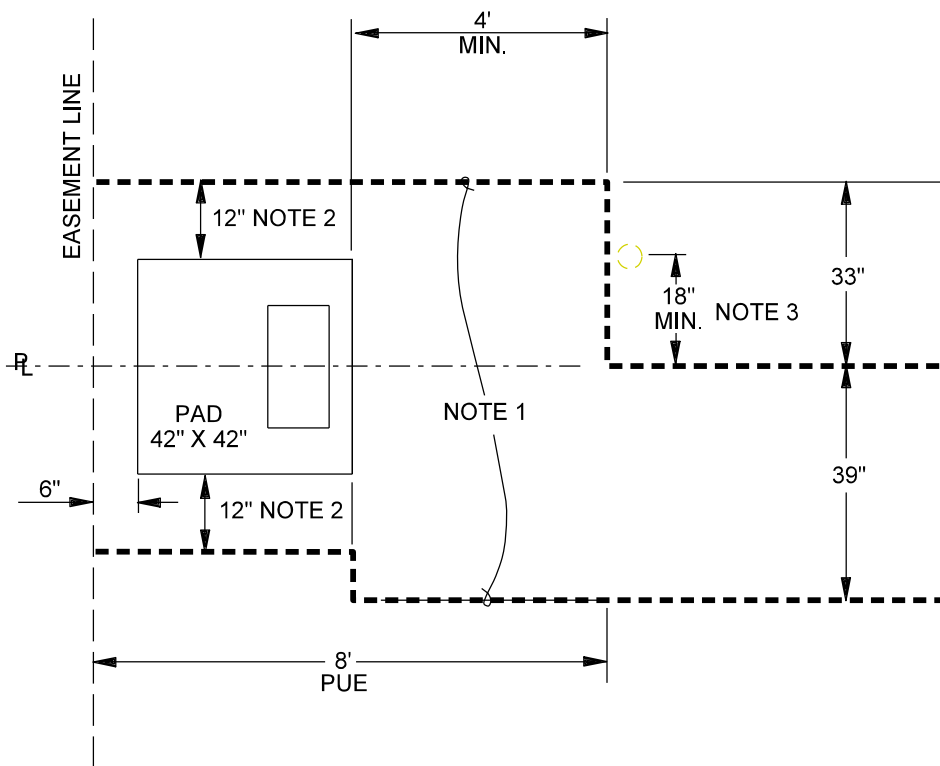

NOTES

1. No Telco or CATV pedestals, water boxes, poles, permanent obstructions or tripping hazards between lines. Clear area is from PUE (house side) to street, or 12' maximum in front of pad.
2. This 12" minimum dimension describes the space requirement between the SRP pad and the Telco or CATV pedestal. When stubbing up Telco or CATV conduit, allow additional space to ensure the Telco or CATV pedestal does not enter the 12" minimum space.
3. If a light pole or other utility is required in this area, it is preferred that it be installed a minimum of 18" from the property line.
4. Bonding shall be provided between all above ground metallic power and communications apparatus (pedestals, terminals, apparatus cases, transformer cases, metal poles, etc.) that are separated by a distance of 6' or less. See Outdoor Lighting Standards page 6-7-1 Light Poles in Proximity of Metallic Apparatus, Bonding.

<p>Electric Service Specifications</p>  <p>PROPRIETARY MATERIAL</p>	<p>CLEARANCES</p> <p>CLEAR AREA FOR CUSTOMER EQUIPMENT</p> <p>ADJACENT TO TRANSFORMER</p>	<p>ISSUE DATE: 03/08/89</p>
	<p>5-14</p>	<p>REV. DATE: 02/23/17</p> <p>APPROVAL: N.SABBAH</p> <p>8509E48.DGN</p>

SECTION 5: CLEARANCES

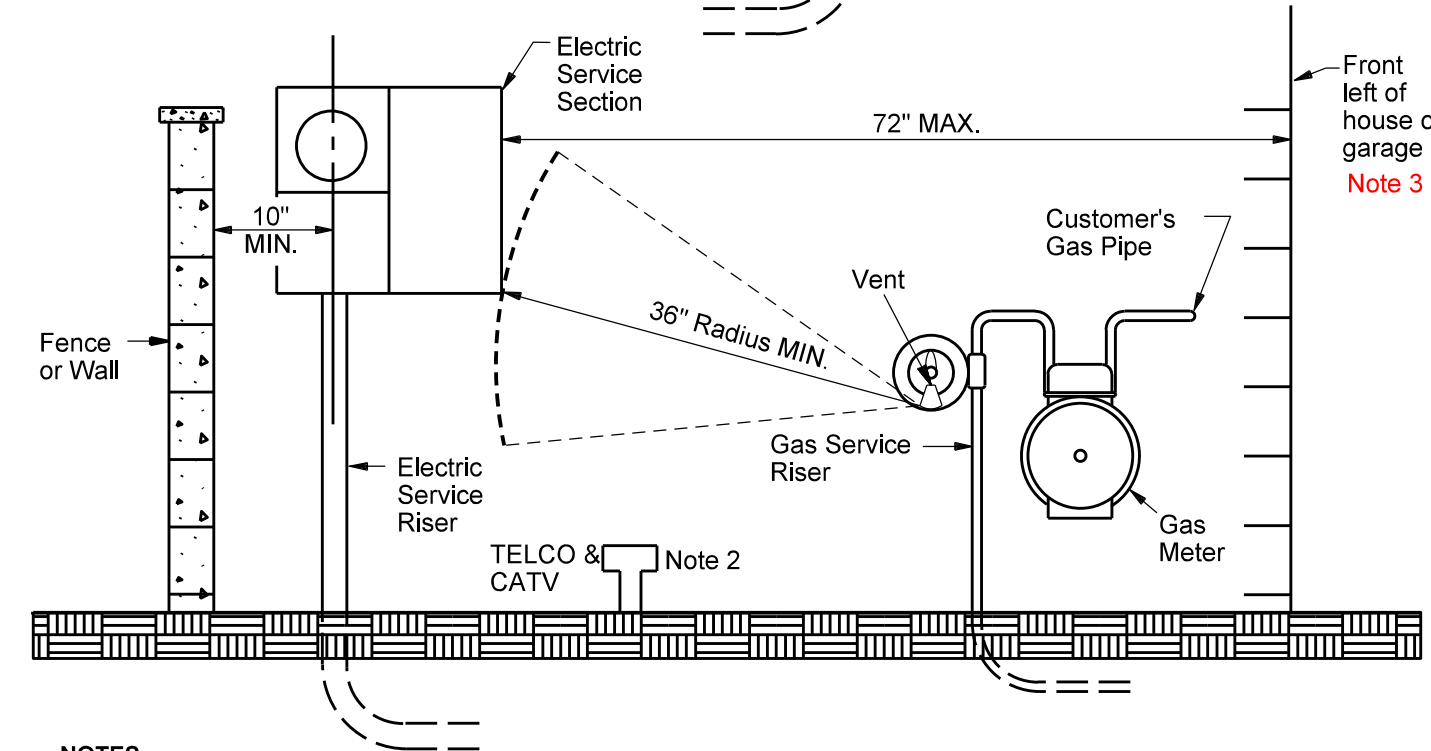
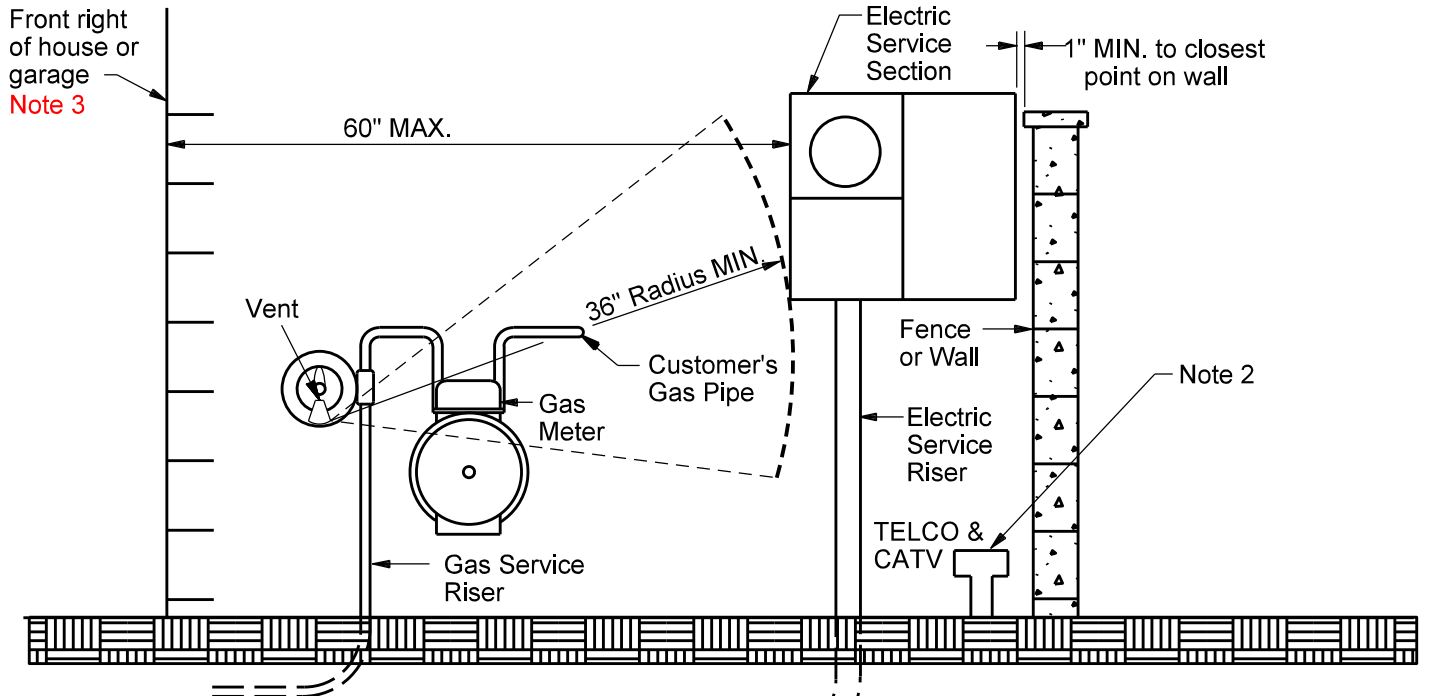

NOTES

1. SES must be readily accessible. See "readily accessible" in the glossary of this book.
2. If non-vented gas lines and TELCO & CATV facilities or water spigots are installed within the 3 square feet working space of the SES, to avoid a trip hazard they shall not extend beyond the front panel of the SES.
3. Exception: If the primary construction is in the backyard or alley the SES may remain in the backyard.

<p>Electric Service Specifications</p>  <p>PROPRIETARY MATERIAL</p>	REV: ADDED NOTE 3	Page 1 of 3
	<p>CLEARANCES SERVICE ENTRANCE SECTION (SES) EQUIPMENT LOCATIONS</p>	
	5-15	<p>ISSUE DATE: 04/15/86 REV. DATE: 10/01/20 APPROVAL: J. Luera</p>

ON STRUCTURE

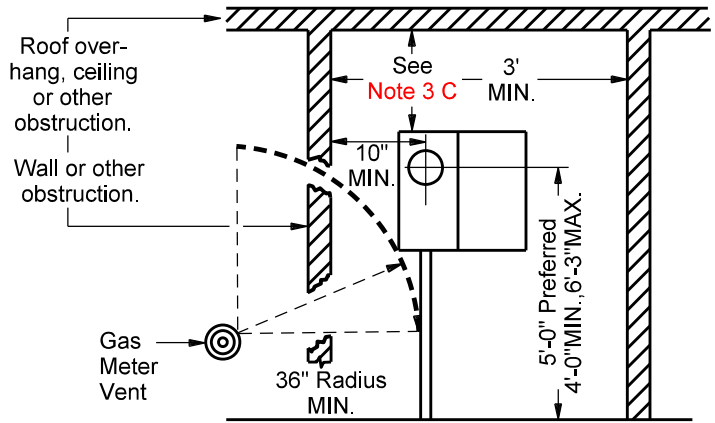
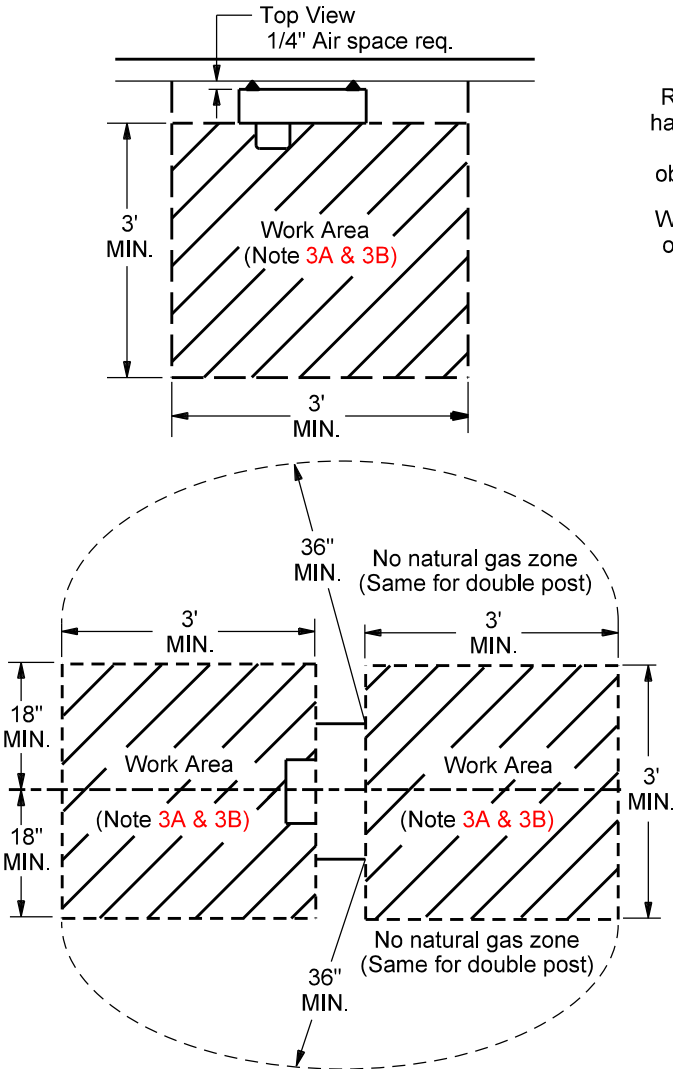

**ON METER POST
TOP VIEW**

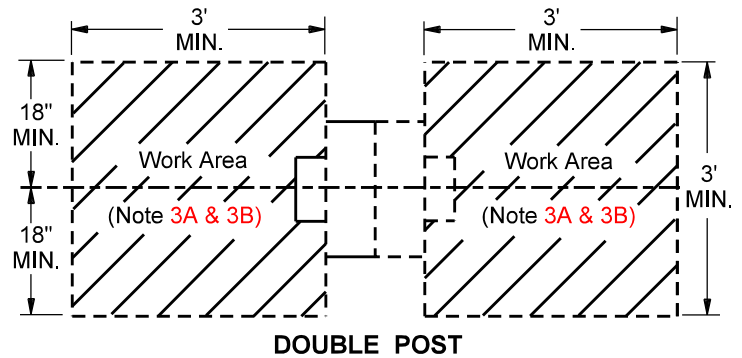

NOTES

1. All heights are measured from the standing surface to the centerline of the meter.
2. When meters are mounted outdoors, the minimum height of the center of the meter shall not be less than 4' and the maximum height shall not exceed 6'-3" from final grade. The preferred height is 5' from final grade.
3. WORKING SPACE (SRP REQUIREMENTS):
 - A. To permit access to SES installations and to provide safety for personnel, an unobstructed, flat and level working and standing space, entirely on the property of the Customer, is to be provided in front of all SES equipment. Access to this work space shall be readily accessible. Vehicle parking is not allowed in this area. All clearances must be at least as shown above.
 - B. Workspace will be minimum 60" from the edge of drivable path.
 - C. Clear vertical space will be minimum 42" for 320 amps to 800 amps service, and 12" for 225 amps (or less) service. The total height for working clearances shall be no less than 6'-6".
4. GUARD POSTS
The Customer will furnish, install and maintain, or make a contribution in aid of construction to SRP (at SRP's option) for permanent guard posts to provide protection where the working space is exposed to vehicles or hazardous conditions. The determination of need, type, size and location of guard posts is at the sole discretion of SRP.

<p>Electric Service Specifications</p>  <p>PROPRIETARY MATERIAL</p>	<p>REV: SWAPPED NOTE ORDER FOR NOTES 3B AND 3C AND UPDATED NOTE CALLOUTS</p>	<p>PAGE 2 OF 3</p>
	<p>CLEARANCES SERVICE ENTRANCE SECTION LOCATIONS HEIGHTS & WORKING SPACE CLEARANCE</p>	
<p>5-16</p>	<p>ISSUE DATE: 04/15/86 REV. DATE: 05/23/19 APPROVAL: N.SABBAAH</p>	<p>8509E118.DGN</p>

NOTES

1. Typical of new construction, when SRP conducts electrical panel inspections, the location of the vent is unknown because it has yet to be installed. In this case, it is the responsibility of the gas company, as the last utility in, to comply with the Arizona Corporation Commission (ACC) requirement. This condition shall not be cause to fail an installation.
2. If the natural gas vent is installed when SRP conducts electrical panel inspections, the distance shall be measured. If the distance does not comply with the ACC requirement, the gas company shall be notified of the violation. This condition shall not be the cause to fail an installation.

NOTE: The gas company has 90 days to comply with the ACC requirement.
3. Gas equipment shall not be within the SES workspace, see "Heights & Workspace Clearance".

<p>Electric Service Specifications</p>  <p>PROPRIETARY MATERIAL</p>	Page 3 of 3	
	<p>CLEARANCES SERVICE ENTRANCE SECTION EQUIPMENT LOCATIONS</p>	<p>ISSUE DATE: 04/15/86 REV. DATE: 03/22/13 APPROVAL: W.LARAMIE</p>
	<p>5-17</p>	<p>8509E324.DGN</p>

Pad-Mounted Facility, Commercial SES, Meter Room or Vault with One-Way Direct (straight) Access to the Front of the Equipment or Access Door (PLAN VIEW)

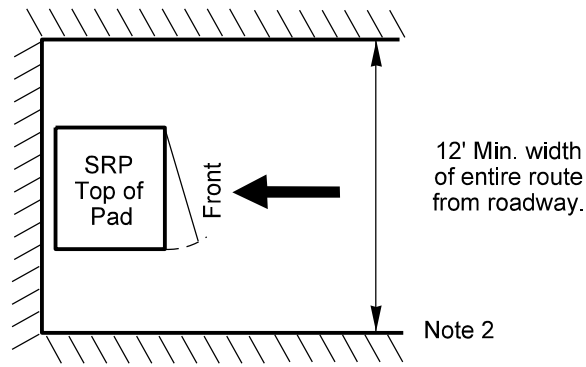

Pad-Mounted Facility, Commercial SES, Meter Room or Vault with a One-Way Direct (straight) Access to the Front from the Side of the Equipment or Access Door (PLAN VIEW)

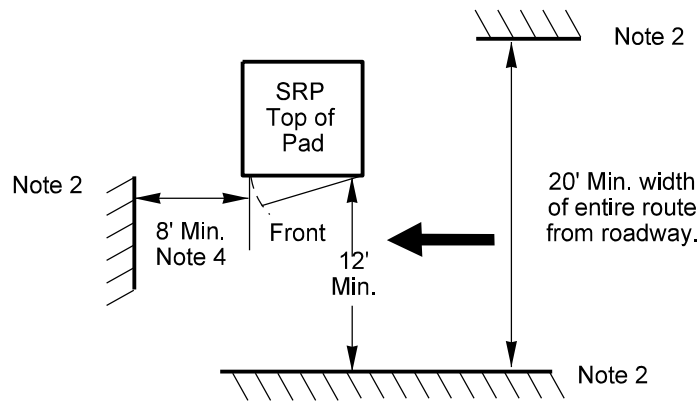

Pad-Mounted Facility, Commercial SES, Meter Room or Vault with One-Way Indirect (requiring a turn) Access to the Front from the Side of Equipment or Access Door (PLAN VIEW)

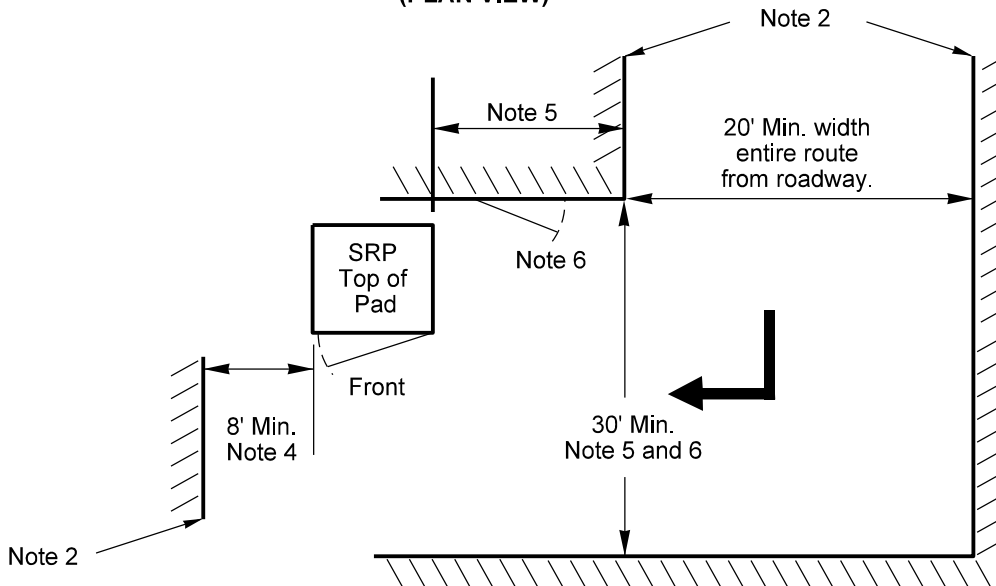

<p>Electric Service Specifications</p>  <p>PROPRIETARY MATERIAL</p>	<p>REV. REVISED VIEW DESCRIPTIONS</p>	<p>ISSUE DATE: 02/09/11</p>
	<p>CLEARANCES VEHICLE ACCESS REQUIREMENTS PAD-MOUNTED FACILITIES & 1Ø TRANSFORMERS</p>	<p>REV. DATE: 06/05/19</p>
	<p>5-18</p>	<p>APPROVAL: N.SABBAH</p>
		<p>8509E319.DGN</p>

**Pad-Mounted Facilities Access Height Clearance Requirements
(PROFILE VIEW)**

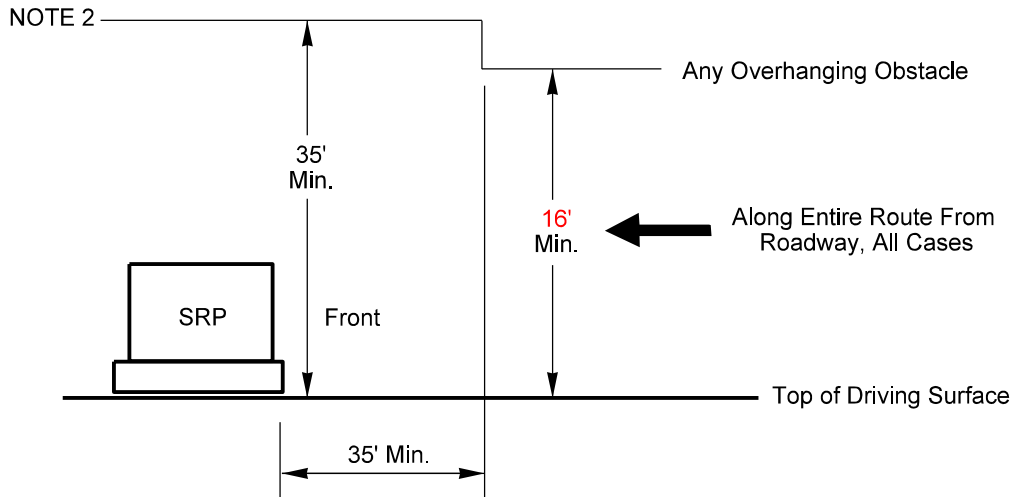

NOTES

1. These required access dimensions are in addition to the electrical clearance standards. See SRP's Electric Clearance Standards.
2. The Boundary of Traveled Way is any permanent obstacle to vehicle access; (i.e., building, fence, Customer equipment, landscape, ditch, curb, etc.).

Boundary of Traveled Way

3. If proposed access route is different than any of the ones shown in these details, consult a Construction Specialist. These requirements are based on bucket truck maneuvering requirements.
4. 8' minimum clear space is required for backing and positioning beyond the equipment.
5. If SRP pad is over 40' beyond corner of turn, the width of the traveled way may be reduced from 30' to 20'.
6. For meter room or vault doors, the width of the traveled way may be reduced from 30' to 20'.
7. There are additional access requirements for vaults with hatches. Consult SRP Distribution Design.

<p>Electric Service Specifications</p>  <p>PROPRIETARY MATERIAL</p>	<p>REV. CLEARANCE HEIGHT UPDATE</p>	<p>ISSUE DATE: 02/09/11</p>
	<p>CLEARANCES VEHICLE ACCESS REQUIREMENTS PAD-MOUNTED FACILITIES & 1Ø TRANSFORMERS</p>	<p>REV. DATE: 06/01/18</p>
	<p>5-19</p>	<p>APPROVAL: N.SABBAH</p> <p>8509E347.DGN</p>

**One-Way Direct (straight) Access to the Front of the Transformer
(PLAN VIEW)**

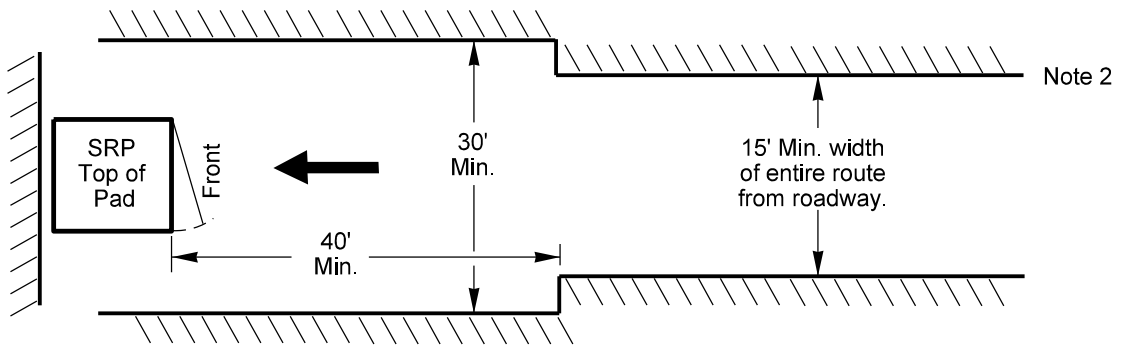

**One-Way Direct (straight) Access to the Front from the Side of the Transformer
(PLAN VIEW)**

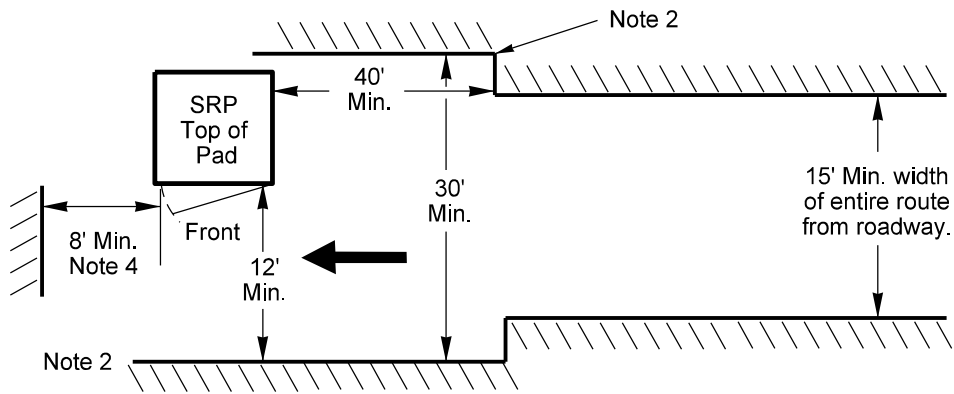

**Three Phase Transformer with One-Way Indirect (requiring a turn) Access
to the Front from the Side of the Transformer
(PLAN VIEW)**

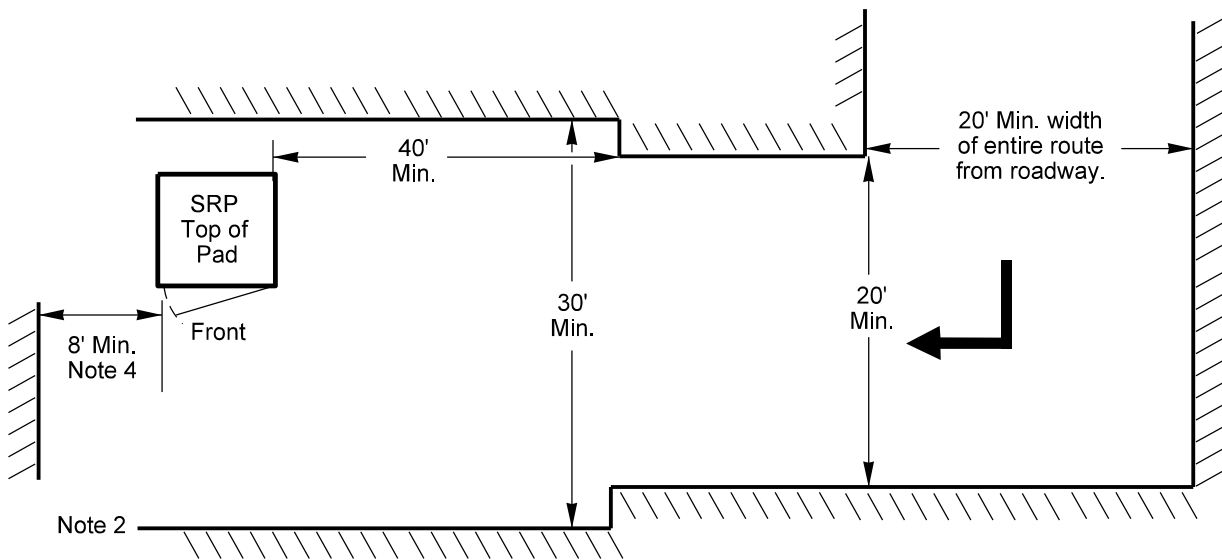

<p>Electric Service Specifications</p>  <p>PROPRIETARY MATERIAL</p>	<p>REV. EQUIPMENT VERIFICATION</p>	<p>ISSUE DATE: 02/09/11</p>
	<p>CLEARANCES VEHICLE ACCESS REQUIREMENTS 3Ø TRANSFORMERS</p>	<p>REV. DATE: 06/01/18</p>
	<p>5-20</p>	<p>APPROVAL: N.SABBAH</p>
		<p>8509E348.DGN</p>

**3Ø Transformer Access Height Clearance Requirements
(PROFILE VIEW)**

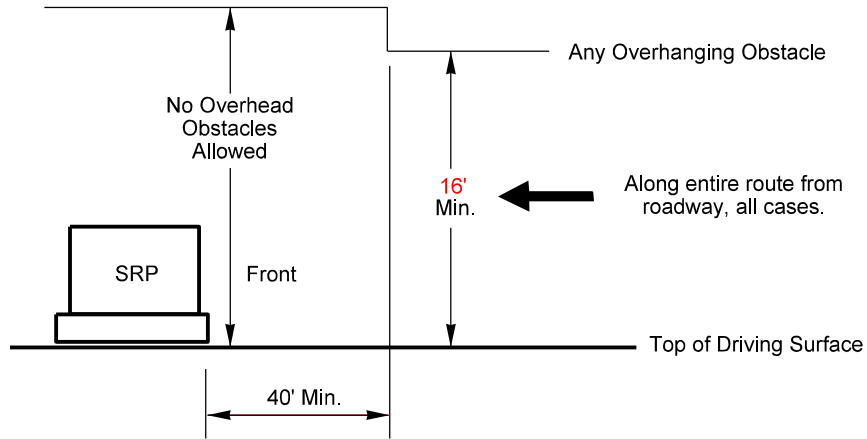

NOTES

1. These required access dimensions are in addition to the electrical clearance standards. See SRP's Electrical Clearance Standards book.
2. The Boundary of Traveled Way is any permanent obstacle to vehicle access (i.e., building, fence, Customer equipment, landscape, ditch, curb, etc.).

Boundary of Traveled Way 

3. These requirements are based on maneuvering requirements of the QMC. If these cannot be obtained, a crane will have to be used. Consult SRP Distribution Design.
4. 8' minimum clear space is required for backing and positioning beyond the equipment.
5. Access way must support 80,000 lbs. GVW.
6. Consult Distribution Design for vehicle access to multiple pad-mounted equipment..

<p>Electric Service Specifications</p>  <p>PROPRIETARY MATERIAL</p>	REV. CLEARANCE HEIGHT UPDATE	
	<p>CLEARANCES VEHICLE ACCESS REQUIREMENTS 3Ø TRANSFORMERS</p>	<p>ISSUE DATE: 02/09/11 REV. DATE: 06/01/18 APPROVAL: N.SABBAH</p>
	5-21	8509E349.DGN

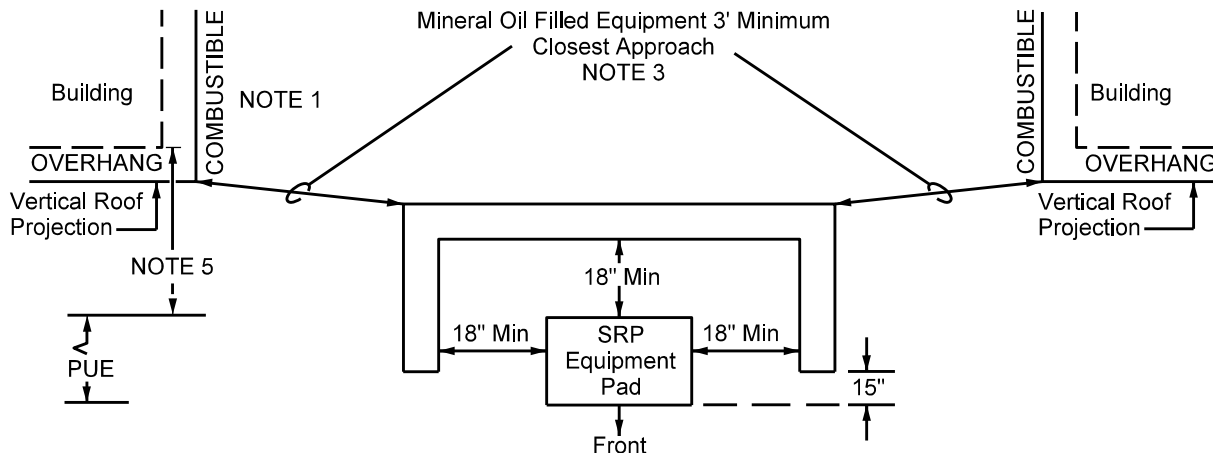
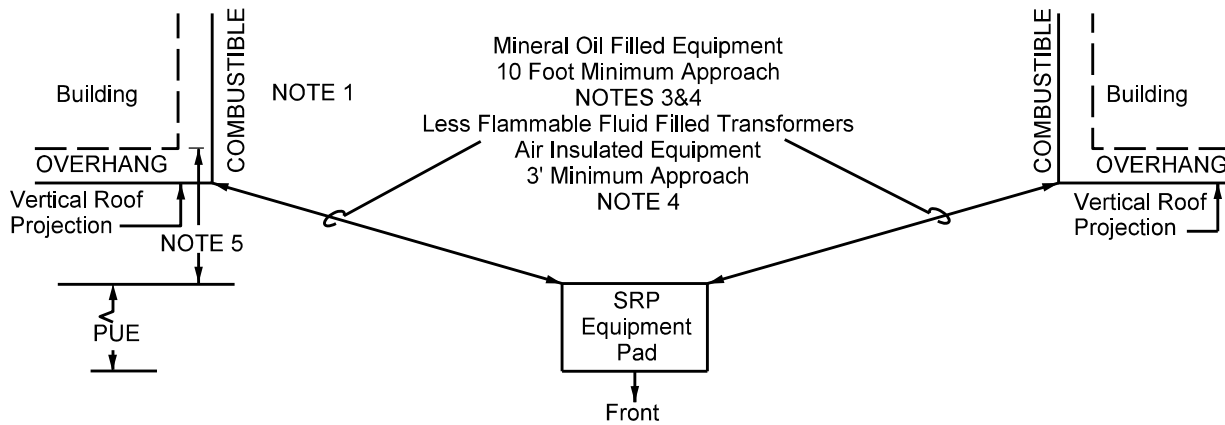

A block masonry wall minimum 8" thick placed around the back and sides of SRP pad-mounted equipment as shown above. Wall height required:

- 1) 1Ø pad-mounted equipment - 45" above grade.
- 2) 3Ø pad-mounted equipment - 1' over device height (see Underground Distribution Line Construction Standards for device height).

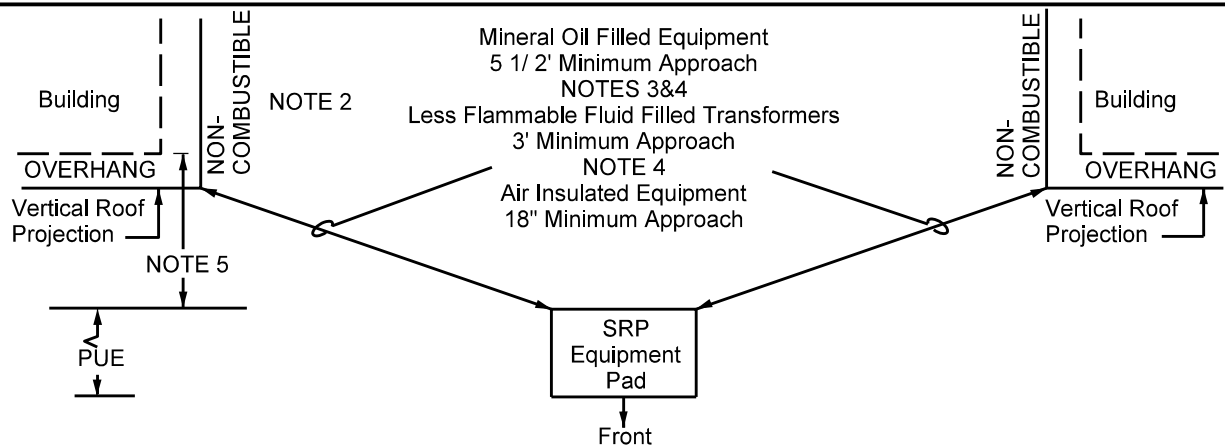

The building wall and overhang is block concrete or approved non-combustible material (Note 2, contact Policy, Procedures & Standards). Building wall has no windows, vents, stairs, doors or other wall openings or a combustible overhang within a 10' minimum closest approach to the pad.

- NOTES:
1. Exterior walls of Type V construction, per IBC Chapter 6, are considered combustible.
 2. Exterior walls of Type I, II, III and IV construction, per IBC Chapter 6, are considered non-combustible.
 3. SRP's mineral oil-filled equipment are standard 1Ø and 3Ø transformers and capacitor banks and some installed fusing cubicles.
 4. Maintain 10' minimum clearance from windows, vents, stairs, doors and/or other wall openings for all mineral oil-filled equipment, and 5' minimum per less flammable fluid-filled transformers.
 5. Building setbacks will be established by local ordinances. Additionally, planned structures shall not impede SRP's access to and excavation of the easement and/or PUE.

 <p>Electric Service Specifications</p> <p>PROPRIETARY MATERIAL</p>	<p>CLEARANCES</p> <p>SRP PAD-MOUNTED EQUIPMENT</p> <p>PAD SEPARATION FROM A BUILDING</p>	<p>ISSUE DATE: 02/16/05</p>
		<p>REV. DATE: 02/10/17</p>
		<p>APPROVAL: N.SABBAH</p>
	<p>5-22</p>	<p>8509E163.DGN</p>

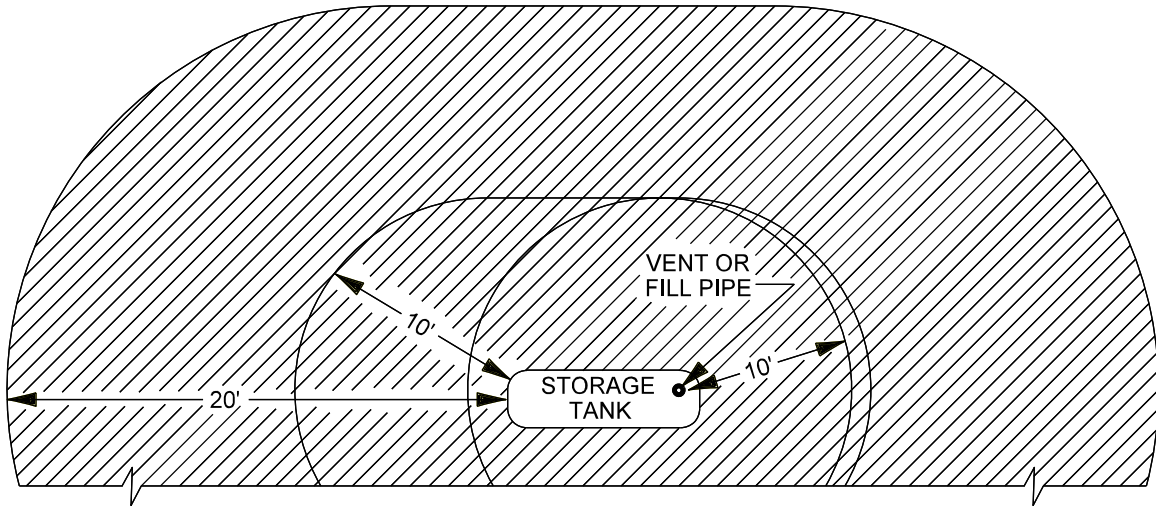

PLAN
(SEE NOTE 1)

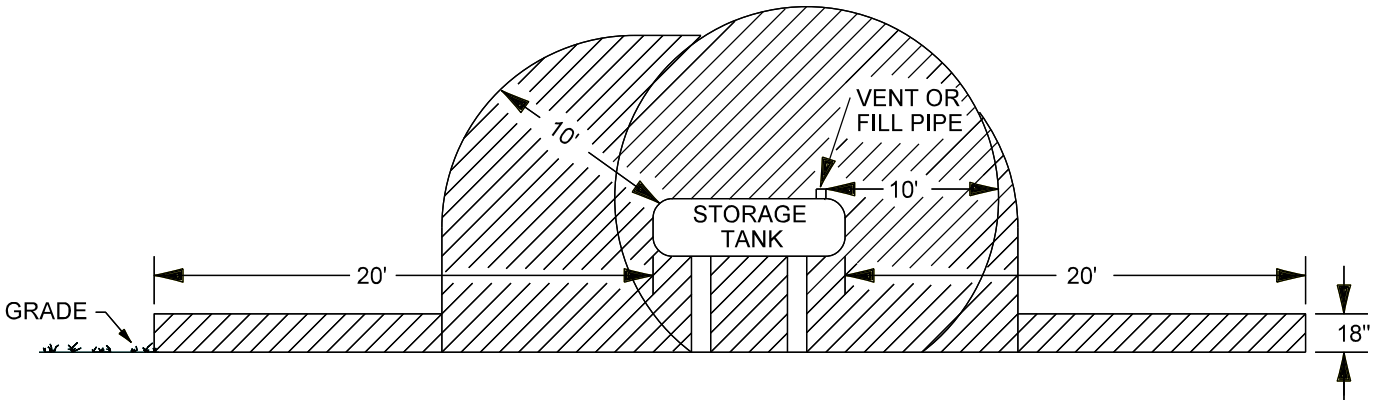

ELEVATION

NOTES

1. No SRP facility shall occupy, underlie or overhang any of the shaded areas.
2. Self-contained diesel generators, or diesel fuel tanks for the generator, shall be at least 10' from any SRP facility.
3. Shall also be used for propane storage tanks.

	CLEARANCES OVERHEAD/ UNDERGROUND ABOVE-GROUND STORAGE TANKS CONTAINING VOLATILE FLAMMABLE LIQUIDS NESC RULE 127	ISSUE DATE: 03/13/07 ISSUE DATE: 11/15/12 APPROVAL: W.LARAMIE
	5-23	8509E272.DGN

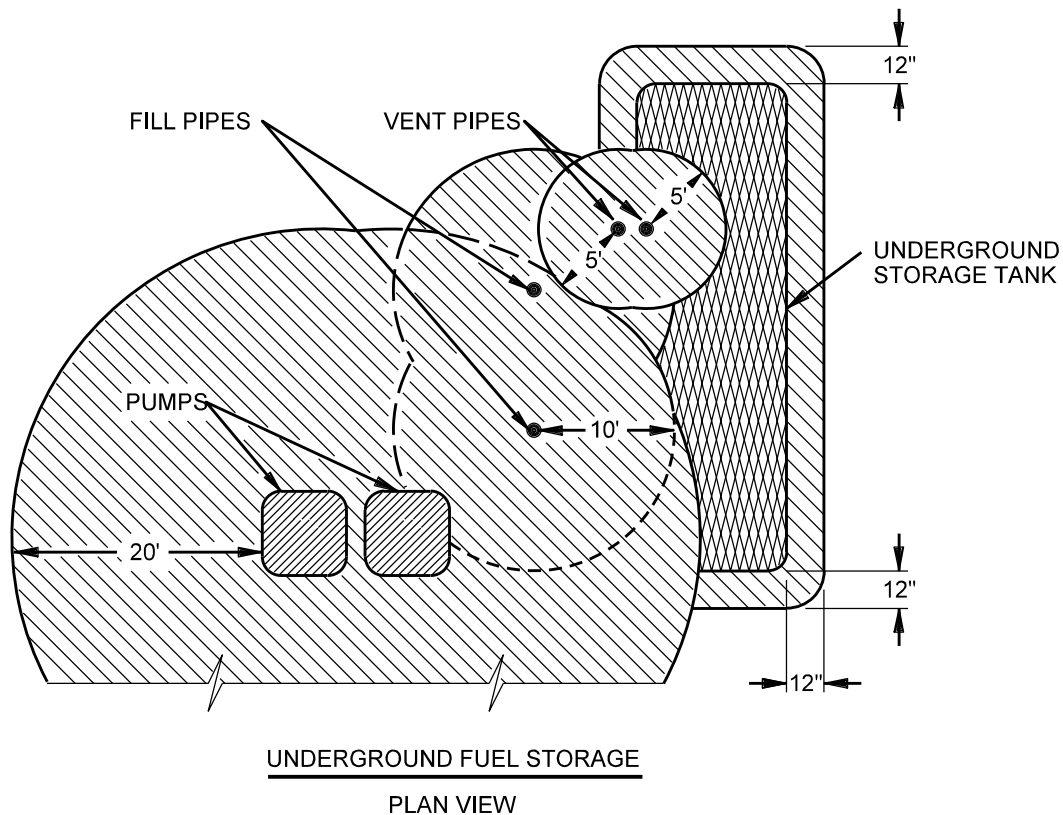

NOTES

1. No underground lines or underground electric facilities shall be located in shaded area.
2. These clearances are for gasoline or other volatile flammable liquids, per NESC rule #127 and NEC Article 515.
3. Self-contained diesel generators, or diesel fuel tanks for the generator shall be at least 10' from any SRP facility.

Electric Service Specifications  PROPRIETARY MATERIAL	CLEARANCES UNDERGROUND CLEARANCES FUEL STORAGE DISPENSING	ISSUE DATE: 03/13/07 REV. DATE: 10/25/12 APPROVAL: W.LARAMIE
	5-24	8509E273.DGN